

DC Inverter Multi Split

Models: M5MSX020 A/AR
 M5MSX025 A/AR
 M5MSX030 A/AR



Большая библиотека технической документации

<https://splitsystema48.ru/instrukcii-po-ekspluatácii-kondicionerov.html>

каталоги, инструкции, сервисные мануалы, схемы.

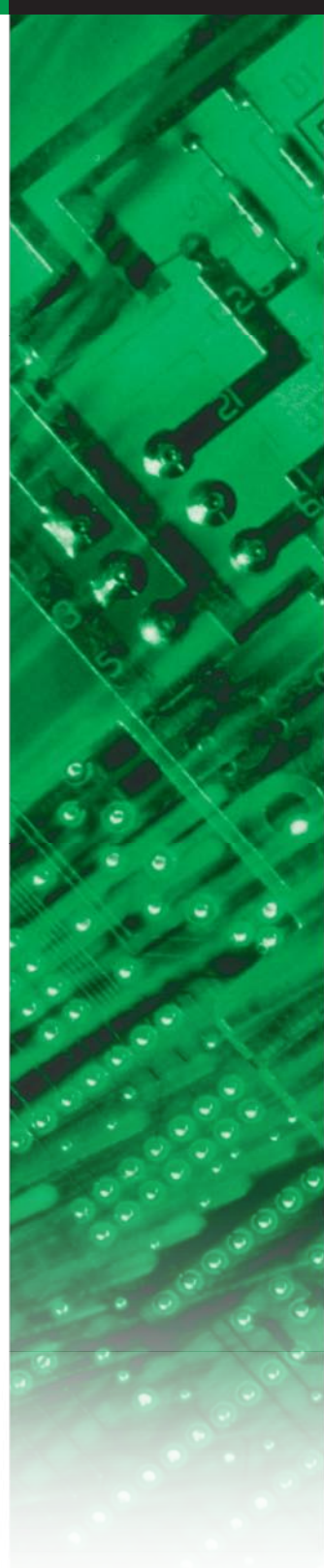

Table of Contents

Nomenclature	1
-Product Line up	
Features	4
Application Information	5
- Operating Range	
- Refrigerant Circuit Diagrams	
- Controllers	
- Installation	
Engineering and Physical Data	25
-Specifications	
Performance Data	41
- Performance Table	
Dimensional Data	44
Electrical Data	48
Wiring Diagram	52
Servicing and Maintenance	55
Troubleshooting	56
Exploded View and Part List	60

This manual supercedes M5MSX-2007

Note : Installation and maintenance are to be performed only by qualified personnel who are familiar with local codes and regulations, and experienced with this type of equipment.

Caution : Sharp edges and coil surfaces are a potential injury hazard. Avoid contact with them.

Warning : Moving machinery and electrical power hazard. May cause severe personnel injury or death. Disconnect and lock off power before servicing equipment.

"McQuay" is a registered trademark of McQuay International. All rights reserved.

© 2008 McQuay International. All rights reserved throughout the world.

Bulletin illustrations cover the general appearance of McQuay International products at the time of publication.

We reserve the right to change design and construction specifications at any time without notice.



Nomenclature

Indoor

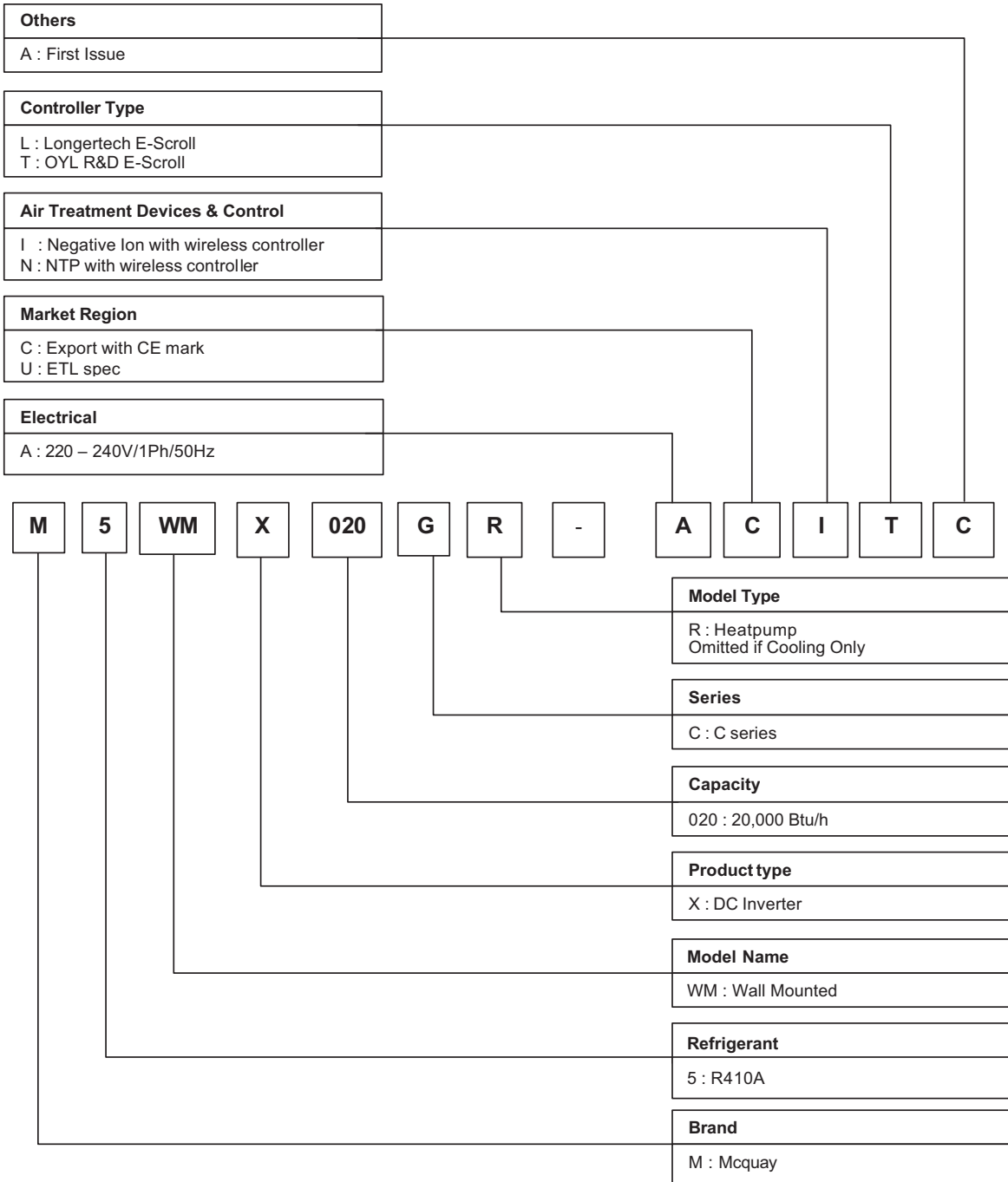

Outdoor

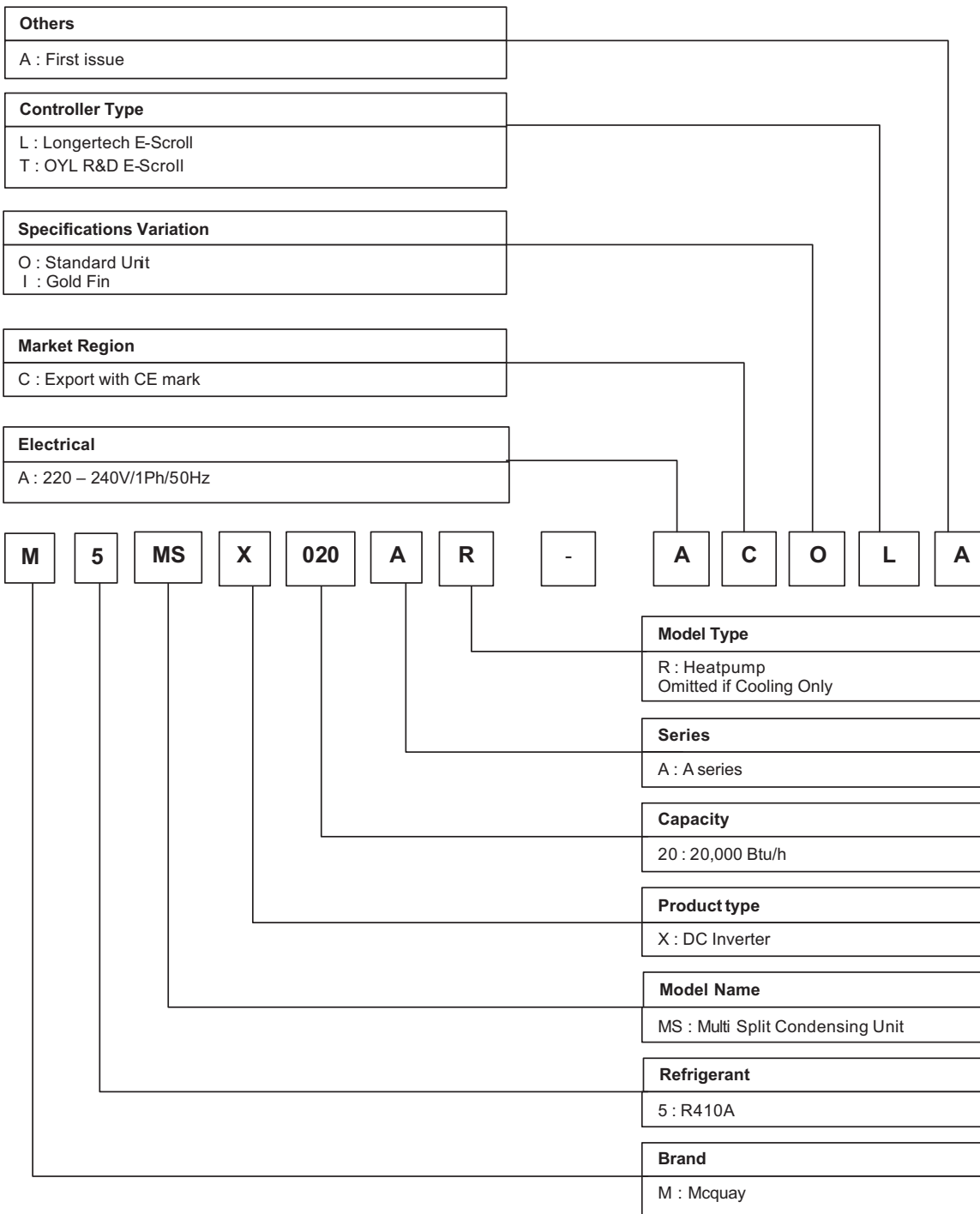

M5MSX-A/AR Product line-up

	M5MSX	Nomenclature	Classification						
			PCB		Rf Control	Compressor		Marking	Grille
			DC INVERTER (LJ DSCAA)	EXV	DC Inv.Twin Rotary	DC Inv.Scroll Comp.	CE Marking	W/O CE Marking	Drain Elbow
Cooling Only	020A	ACOLA	X	X		X	X		X
	025A	ACOLA	X	X	X		X		X
	030A	ACOLA	X	X	X		X		X
Heat Pump	020AR	ACOLA	X	X		X	X		X
	025AR	ACOLA	X	X	X		X		X
	030AR	ACOLA	X	X	X		X		X

M5WMX-G/GR Product line-up

	M5WMX	Nomenclature	Classification							
			Handset		PCB		Air Purification		Marking	
			G11	VA2.0	LJID 1.0	Negative Ion	Nano Filter	NTP	CE	NO
Cooling Only	010G	ACITC	X	X		X	X		X	
	015G	ACITC	X	X		X	X		X	
	020G	ACITC	X	X		X	X		X	
Heat Pump	010GR	ACITC	X	X		X	X		X	
	015GR	ACITC	X	X		X	X		X	
	020GR	ACITC	X	X		X	X		X	

Features

Higher Energy Savings

The compressor in McQuay DC Multi Split Inverter is programmed to run at the optimum speed. The compressor speed is controlled by input frequency that varies according to the indoor load requirements. Once the indoor set temperature is achieved, the input frequency supply to the compressor will be reduced. Hence, less energy is required to maintain the unit operation and this will consume less energy.

Fast Cooling

During the unit start up, the inverter air-conditioner system takes a shorter period to achieve the set room temperature than conventional air-conditioner systems. Thus, the inverter system offers fast cooling features.

Low Starting Current

Taking advantage of the ability to modulate the compressor speed, inverter models are designed with “soft starter” feature. The compressor motor will not draw high current during start up.

Zero-Ozone Depleting Potential Refrigerant

Introducing the new type of refrigerant – R410A which is environmental friendly with Zero Ozone Depletion Potential (ODP = 0). R410A also provides the higher volumetric capacity and better refrigerating effect per unit of volume.

Advance Technology

The traditional conventional air conditioners repeat “the start” and “the stop” during the thermostat cycle off and causes the room temperature to be unstable. Incorporating fuzzy logic control into the McQuay DC Multi Split Inverter design enables greater flexibility in handling the system control.

This result in:

- Powerful, efficient and economical operation.
- Even room temperature control.
- Constant and quiet compressor operation.
- Enhanced system reliability and reduced maintenance costs.

Low Noise Operation

McQuay DC Multi Split Inverter System has been designed to use the state-of-the-art, twin rotary compressor. In this compressor, the roller phases are staggered 180° apart from each other. With this design, the centrifugal forces of one roller is counterbalanced by the force of the other roller, whereby reducing the vibration of the compressor. This makes the unit quieter and less vibration.

To further reduce the noise level, brushless DC motor is used. This further reduces noise generated by the fan motor. Additionally, by using a bigger sized fan blade, a lower rpm is possible while maintaining ample airflow.

Improved Compressor Life Span

For the McQuay DC Multi Split Inverter system, once the unit is started, the compressor rotation speed is steadily ramp up or down based on load requirement throughout the operation. This control method gives the compressor motor a smooth operation. It helps to reduce the wear and tear of the compressor motor. In the long run, the life span of compressor is increased.

Application Information

Operating Range

Ensure the operating temperature is in allowable range

Cooling only

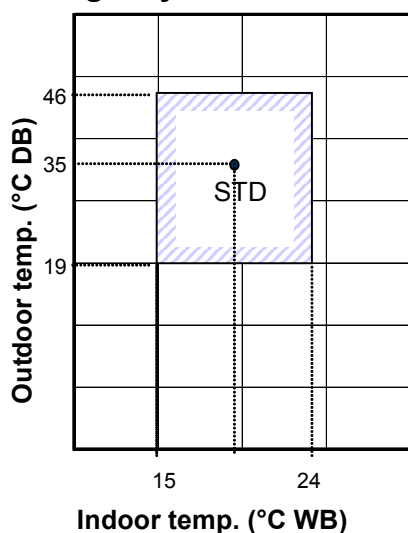

 **Cautions:**

The use of your air conditioner outside the range of working temperature and humidity can result in serious failure.

Heat pump

Heating

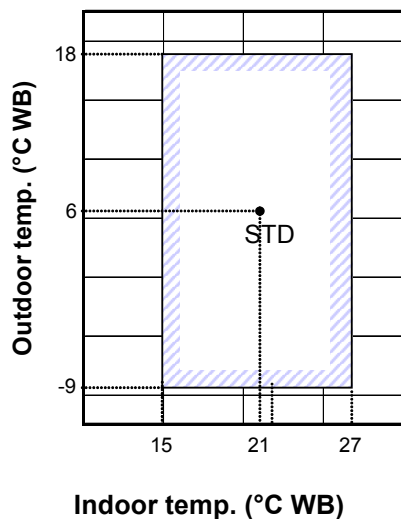

Cooling

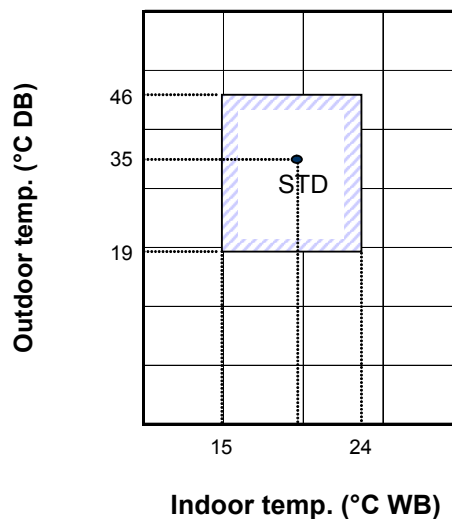

Refrigerant Circuit Diagram

Model : M5MSX 020A

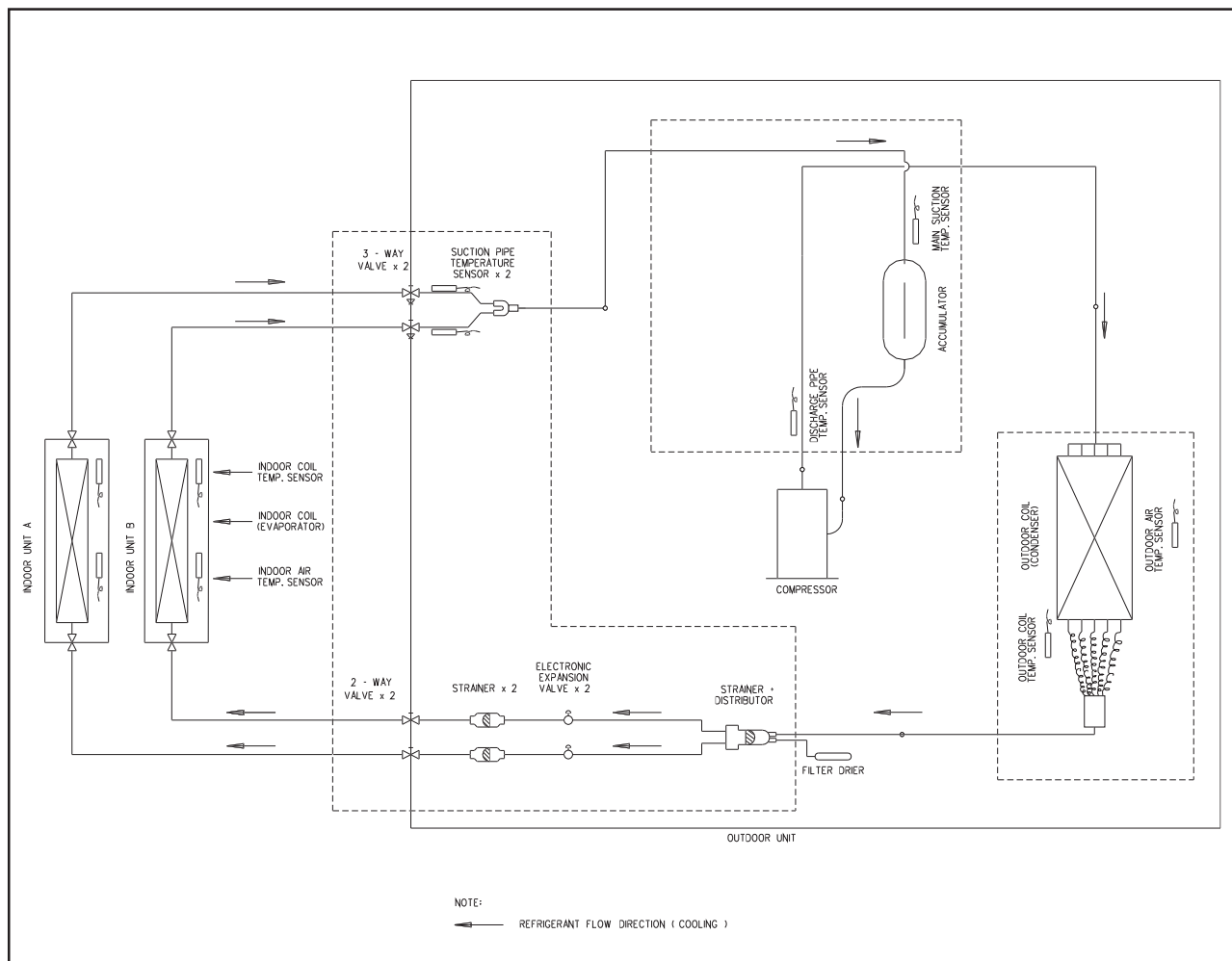

Model : M5MSX 020AR

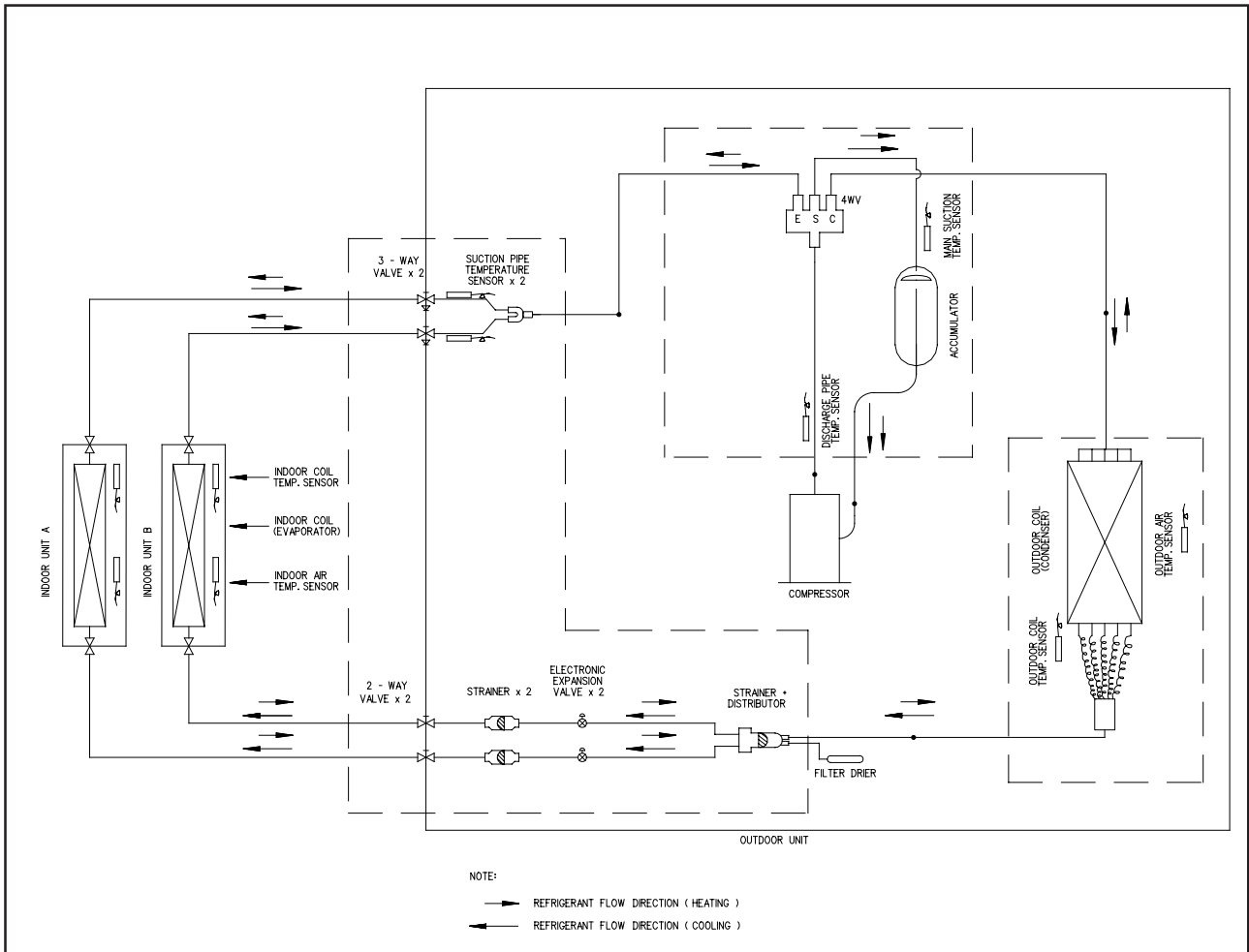

Model : M5MSX 025A

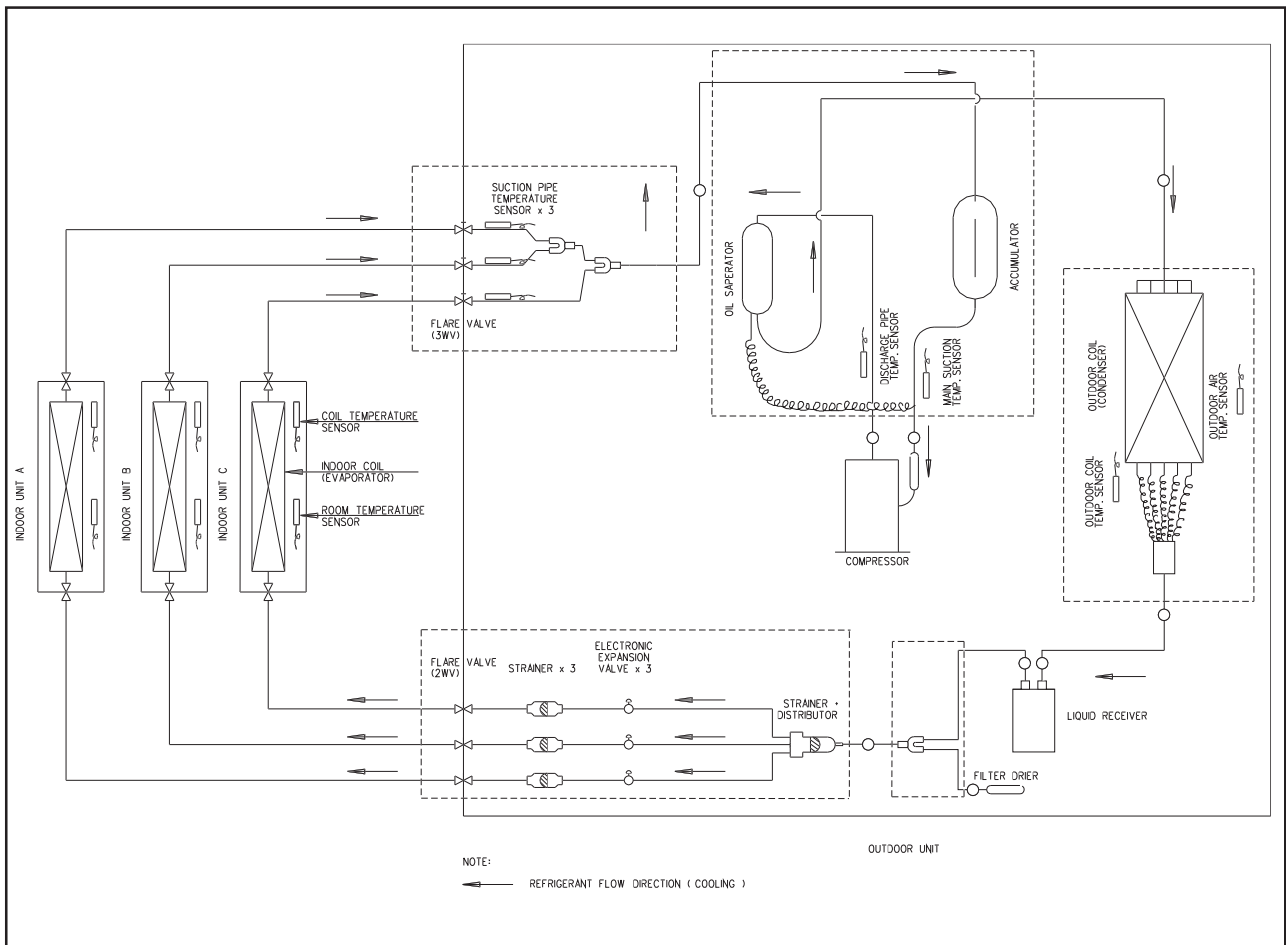

Model : M5MSX 025AR

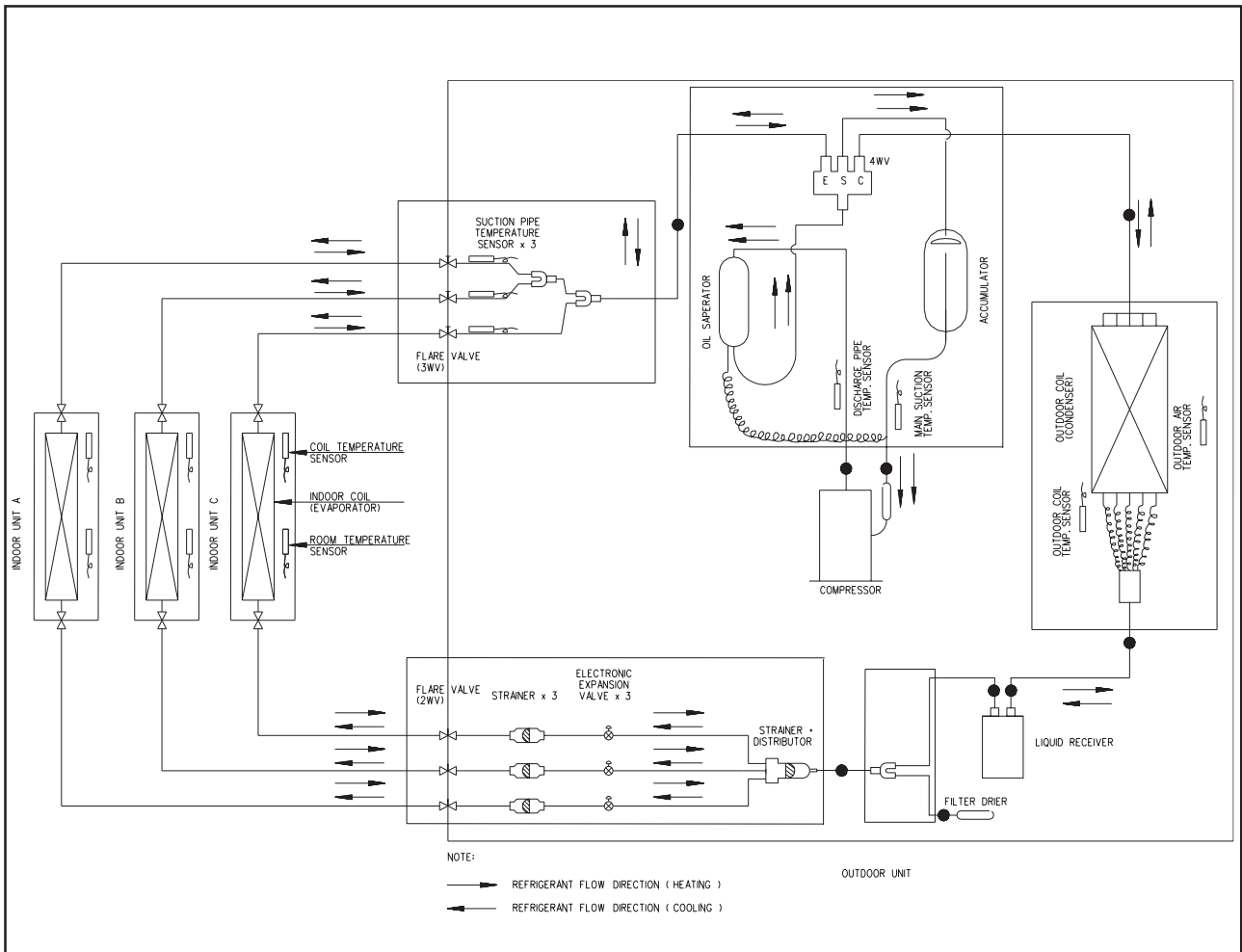

Model : M5MSX 030A

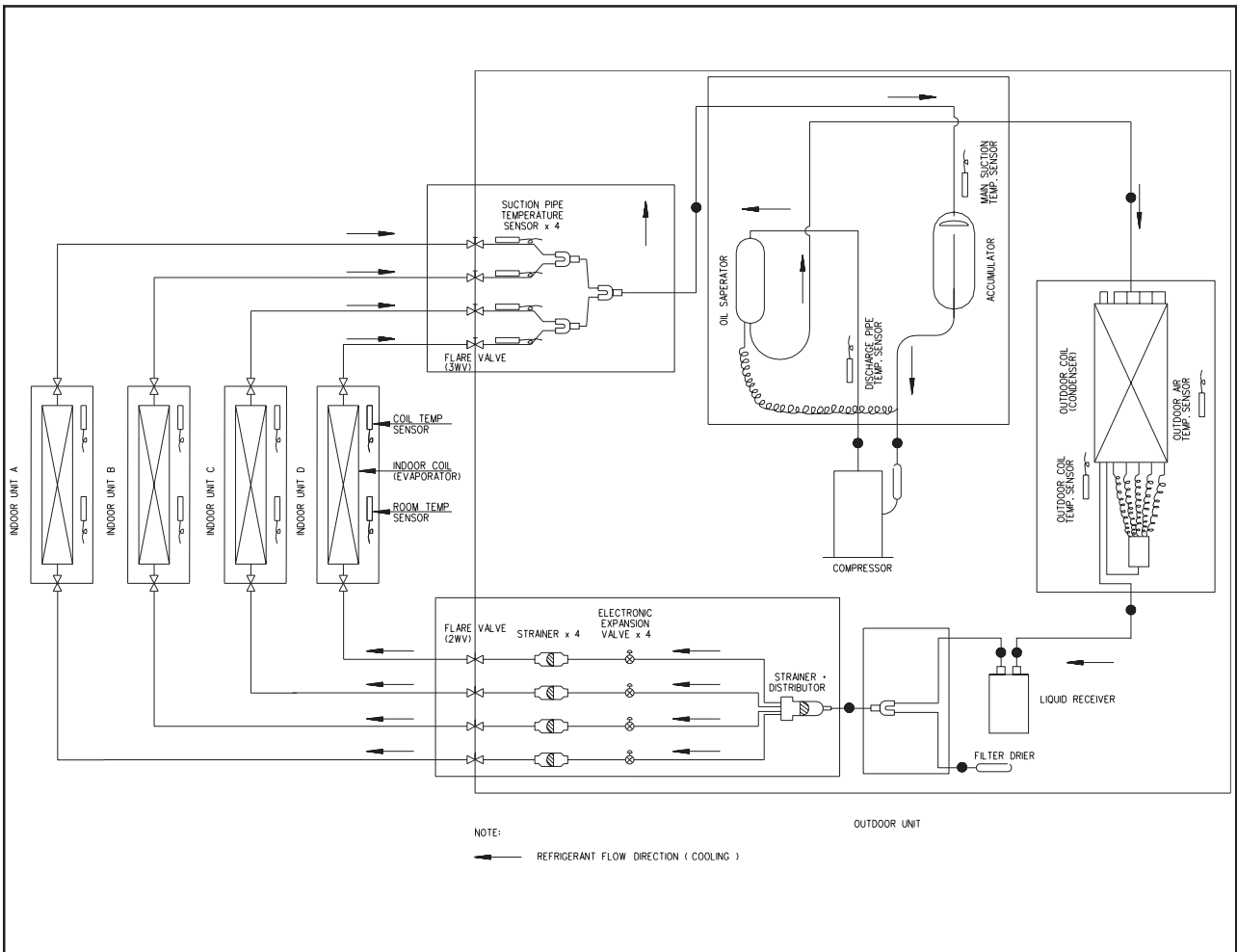

Model : M5MSX 030AR

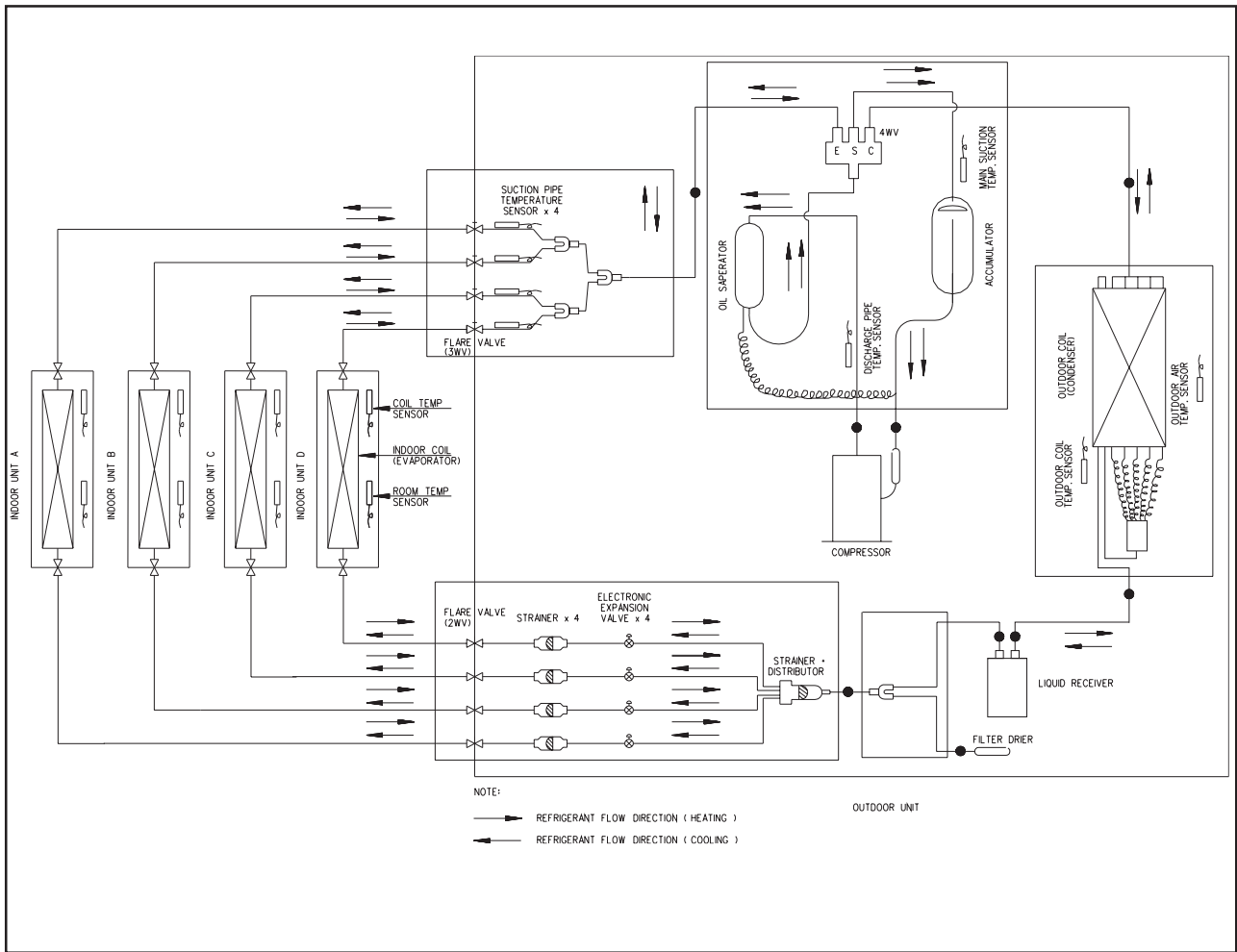

Controllers

G11 Remote Controller

Temperature Setting

- To set the desired room temperature, press the button to increase or decrease the set temperature.
- The temperature setting range is from 16°C to 30°C
- Press both buttons simultaneously to toggle the temperature setting between °C and °F

Turbo Mode

- Press the TURBO button to achieve the required set temperature in a short time.

Sleep Mode

- Press the button to activate sleep mode. This function is available under COOL, HEAT & AUTO mode.
- When it is activated in COOL mode, the set temperature will be increased 0.5°C after 30mins, 1°C after 1 hour and 2°C after 2 hours.
- When it is activated in HEAT mode, the set temperature will be decreased 1°C after 30mins, 2°C after 1 hour and 3°C after 2 hours.

ON Timer Setting

- Press the SET button will activate the on timer function.
- Set the desired on time by pressing the SET button continuously.
- Press the CLR button to cancel the off timer setting

Clock Time Setting

- Press button + or - to increase or decrease the clock time.

Ionizer

- Press the button to activate the negative Ion function, which will refresh the indoor air effectively.

On/Off Button

- Press Once to start the air conditioner
- Press again to stop the unit

Personalised Setting

- Press and hold the button for 3s to initiate personalized setting.
- Set the individual setting e.g. MODE, SET TEMP or FAN SPEED and leave for 4s to save
- 2 groups of settings are allowed to be stored in the handset

Fan Speed Selection

- Press the button until the desired fan speed is achieved.

Operating Mode

- Press the MODE button to select the type of operating mode.
- For Cooling only unit, the available modes are: COOL, DRY & FAN.
- For Heatpump unit, the available modes are: AUTO, COOL, DRY, FAN & HEAT.

OFF Timer Setting

- Press the SET button will activate the off timer function.
- Set the desired off time by pressing the SET button continuously.
- Press the CLR button to cancel the off timer setting

Automatic Air Awing

- Press the SWING button to activate the automatic air swing function.
- To distribute the air to a specific direction, press the SWING button and wait until the louver move to the desired direction and press the button once again.

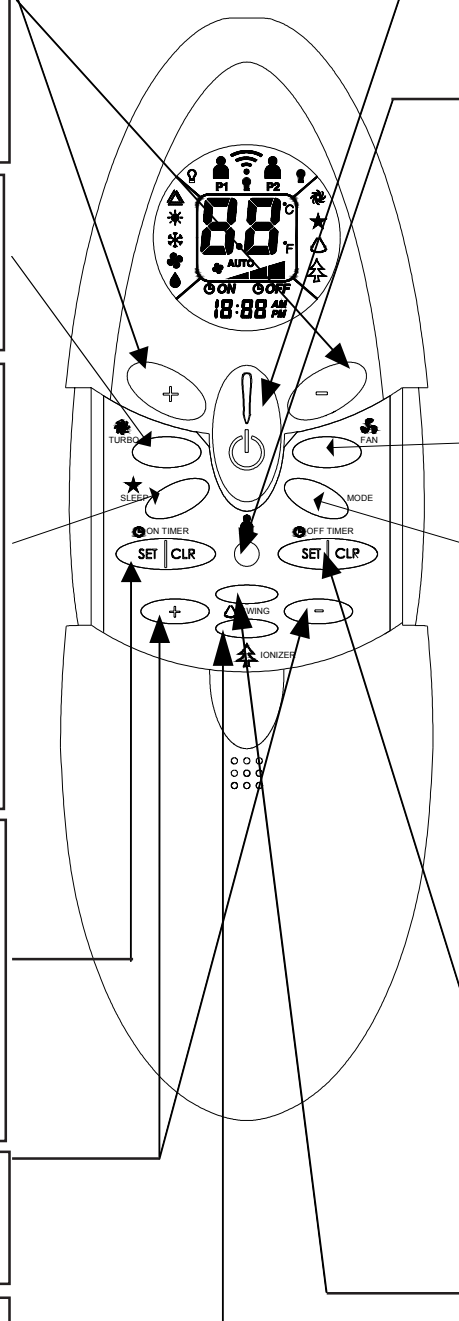

* Depends on Specifications

Installation

Safety Precautions

Before installing the air conditioner unit, please read the following safety precautions carefully



Warning

- Installation and maintenance should be performed by qualified persons who are familiar with local code and regulation, and experienced with this type of appliance.
- All field wiring must be installed in accordance with the national wiring regulation.
- Ensure that the rated voltage of the unit corresponds to that of the name plate before commencing wiring work according to the wiring diagram.
- The unit must be GROUNDED to prevent possible hazards due to installation failure.
- All electrical wiring must not touch the refrigerant piping, compressor or any moving parts of the fan motors.
- Confirm that the unit has been switched OFF before installing or servicing the unit.
- Do not touch the compressor or refrigerant piping without wearing gloves.

IMPORTANT: DO NOT INSTALL OR USE THE AIR CONDITIONER UNIT IN A LAUNDRY ROOM

Caution

Please take note of the following important points when installing.

- **Do not install the unit where leakage of flammable gas may occur.**



If gas leaks and accumulates around the unit, it may cause fire ignition.

- **Ensure that the drainage piping is connected properly.**



If the drainage piping is not connected properly, it may cause water leakage which will dampen the furniture.

- **Do not overcharge the unit.**



This unit is factory pre-charged. Overcharge will cause over-current or damage to the compressor.

- **Ensure that the units panel is closed after service or installation.**



Unsecured panels will cause unit to operate noisily.

Installation of the indoor unit

The indoor unit must be installed in such a way so as to prevent short circuit of the cool discharged air with the hot return air. Please follow the installation clearance shown in the figure. Do not place the indoor unit where there could be direct sunlight shining on it. Also, this location must be suitable for piping drainage and be away from doors or windows.

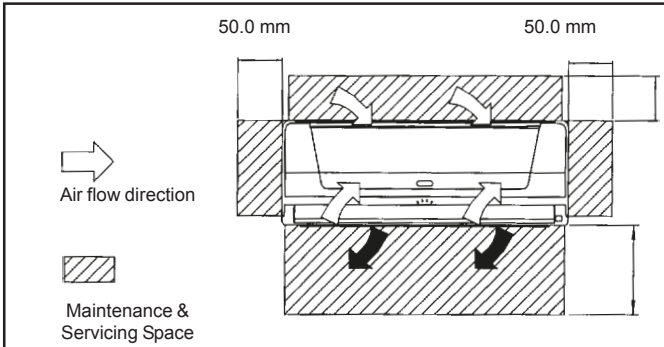

Routing of piping

Remove the screw holding the front panel.

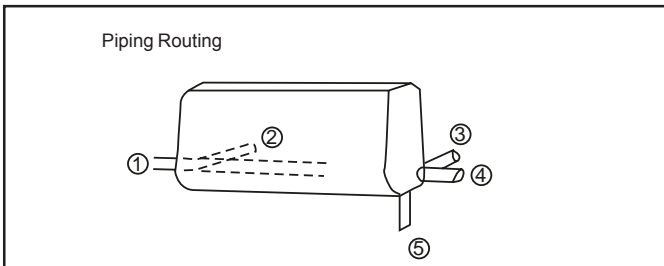

The refrigerant piping can be routed to the unit in a number of ways (left or right from the back of the unit) by using the cut-out holes on the casing of the unit (see figure). Bend the pipes carefully to the required position in order to align it with the holes. For the right hand and rear side out, hold the bottom of the piping and then position it to the required direction (see figure). The condensation drain hose can be taped to the pipes.

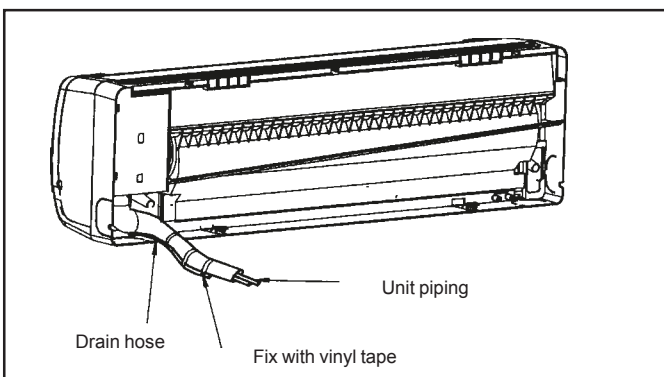

Mounting installation plate

Ensure that the wall is strong enough to withstand the weight of the unit. Otherwise, it is necessary to reinforce the wall with plates, beams or pillars.

Use the level gauge for horizontal mounting, and fix it with 4 suitable screws.

In case the rear piping draws out, drill a hole 65mm in diameter with a cone drill, slightly lower on the outside wall (see figure)

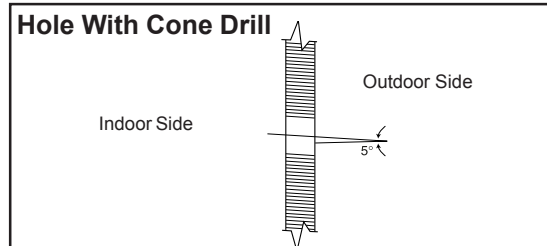
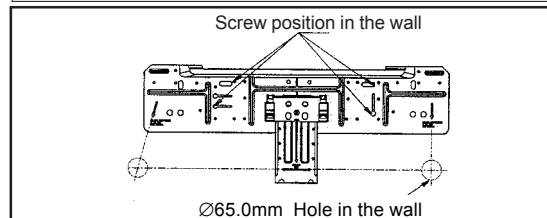
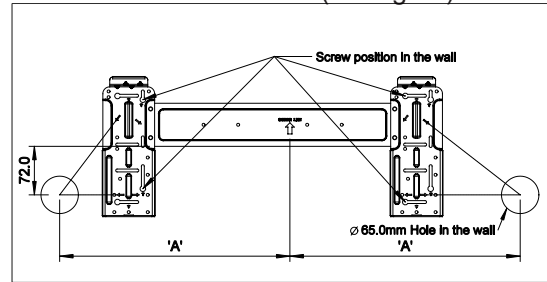

Mount the unit onto the installation plate

Hook the indoor unit onto the upper portion of the installation plate (Engage the two hooks at the rear top of the indoor unit with the upper edge of the installation plate). Ensure that the hook are properly seated on the installation plate by moving it to the left and right.

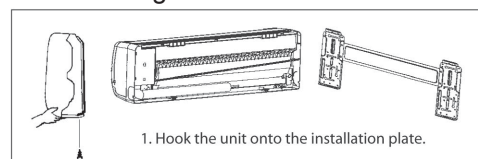

Water drainage piping

The indoor pipe must be in a downward gradient for smooth drainage. Avoid situations that are likely to cause water leak.

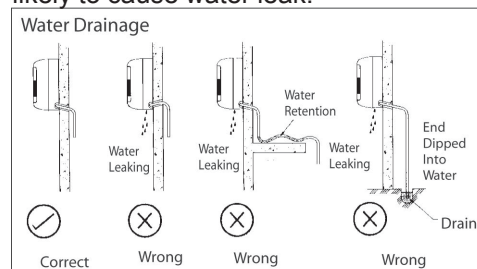

Installation Diagram

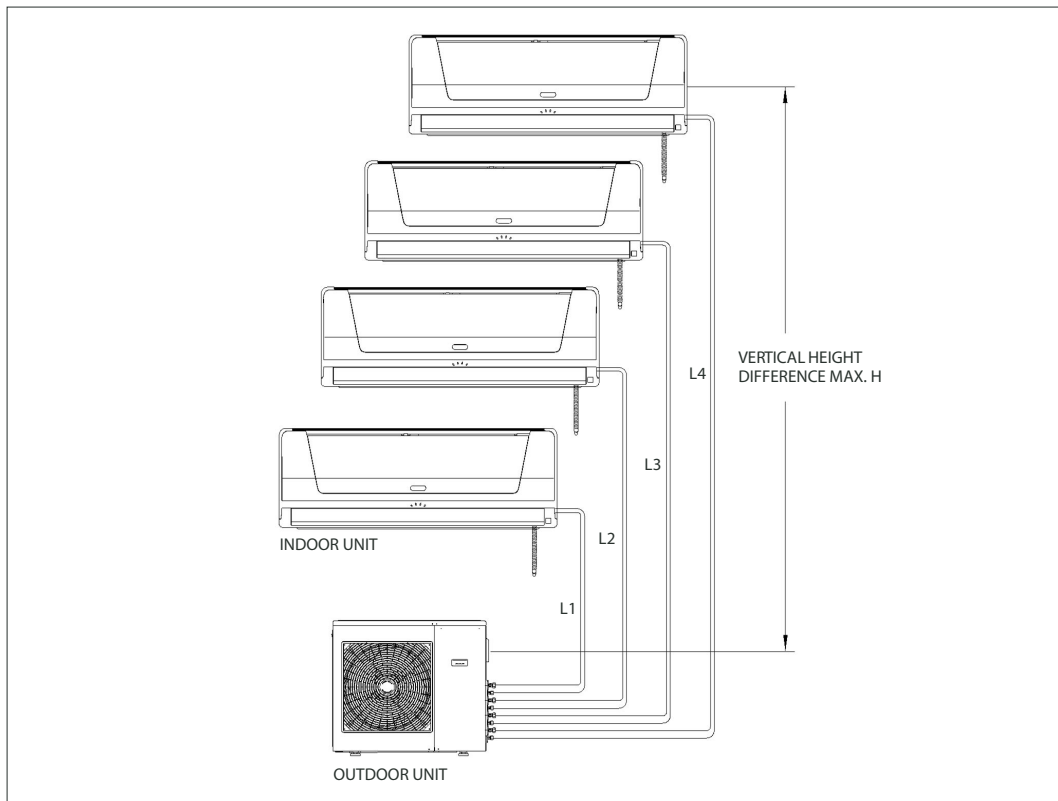

Indoor unit combination for outdoor unit **M5MSX 020A/AR, M5MSX025A/AR and M5MSX030A/AR**

Indoor units with model name M5WMX 010G/GR, M5WMX015G/GR and M5WMX020G/GR could be coupled with this outdoor unit.

The following table shows the possible coupling combinations available.

No	Coupling Combinations (5WMX-G/GR)		
	M5MSX020A/AR	M5MSX025A/AR	M5MSX030A/AR
1	10+10	10+10+10	10+10+10+10
2	10+15	10+10+15	10+10+10+15
3	15+15	10+10+20	10+10+10+20
4		10+15+15	10+10+15+15
5		10+15+20	10+10+15+20
6		15+15+20	10+15+15+15
7			15+15+15+15

For further details on operation combinations, total capacity and other technical specifications, please refer to the technical manual.

Installation of outdoor unit

The outdoor unit must be installed in such a way, so as to prevent short circuit of the hot discharged air or obstruction to the smooth air flow. Please follow the installation clearance shown in the figures below. Select the coolest possible place where intake air temperature is not greater than the outside air temperature (maximum 45°C/113°F).

Note: If there is any obstacle higher than 2m (6.56ft), or if there is any obstruction at the upper part of the unit, please allow more space than the figure indicated in the table shown below.

Installation Clearances

Dimensions	A	B	C	D
Minimum Distance(mm)	300	1000	300	500

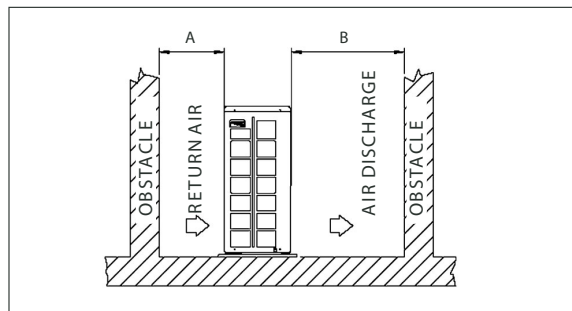
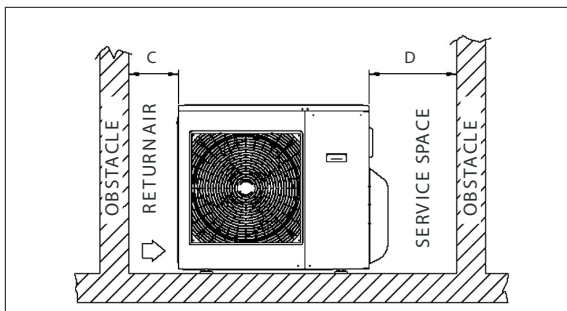

Before installation the piping and connecting cord, please remove the access panel and plastic valve cover or service panel for easy access and safety. Refer to figures shown below.

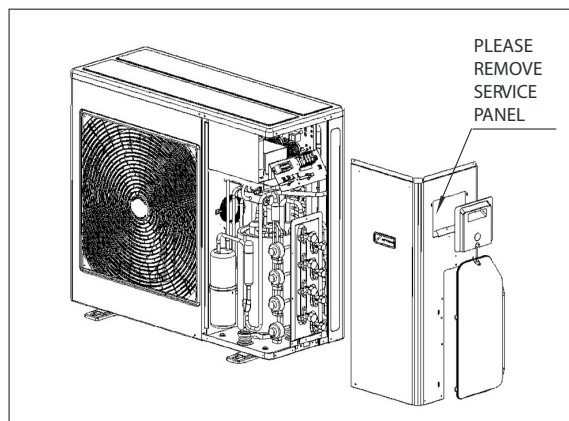
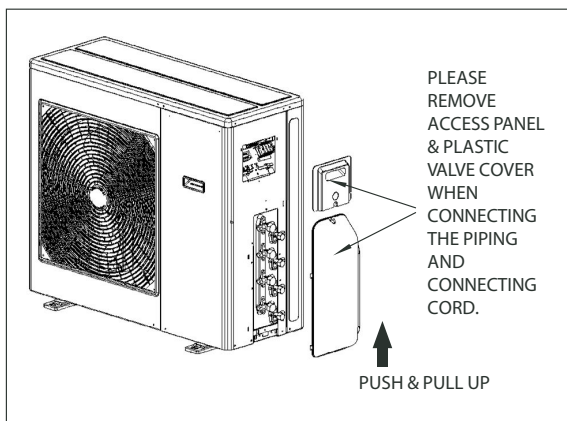

Refrigerant piping work

Piping length and elevation

If the pipe is too long, both capacity and reliability of the unit will drop. As the number of bends increases, resistance to the flow of refrigerant system increases, thus lowering cooling capacity. As a result, the compressor may become defective. Always choose the shortest path and follow the recommendations as tabulated below.

Item	Model	Long Piping			O/D Precharged	Charge Amount for Additional Piping Length		
		M5WMX010 G/GR	M5WMX015 G/GR	M5WMX020 G/GR		20m	25m	30m
1	M5MSX020A/AR (1 to 2)	20	20	20	1650g	20m	25m	30m
		(Total length $L_1+L_2 = 30m$)				0	+100g	+200g
2	M5MSX025A/AR (1 to 3)	20	20	20	2320g	40m	45m	50m
		(Total length $L_1+L_2 + L_3 = 50m$)				0	+100g	+200g
3	M5MSX030A/AR (1 to 4)	20	20	20		40m	50m	60m
		(Total length $L_1+L_2 + L_3+L_4 = 60m$)				0	+200g	+400g

Coupling Model	M5WMX010G/GR	M5WMX015G/GR	M5WMX020G/GR
Max. Elevation, H (m/ ft)	5	5	5
Max. Number of Bends	10	10	10
Liquid Pipe Size	1/4"	1/4"	1/4"
Gas Pipe Size	3/8"	1/2"	1/2"

Individual indoor unit can have a maximum length of 20 m (65.6ft), maximum elevation of 5 m (32.8ft) and maximum number of bends of 10, however, the total pipe length must not exceed 30m (M5MSX020AR), 50m (M5MSX025AR) or 60m (M5MSX030AR) depending on the model of the outdoor unit.

Remark: The refrigerant pre-charged in the outdoor unit is for total piping length up to 20m for model M5MSX020A/AR and 40m for model M5MSX025A/AR and M5MSX030A/AR.

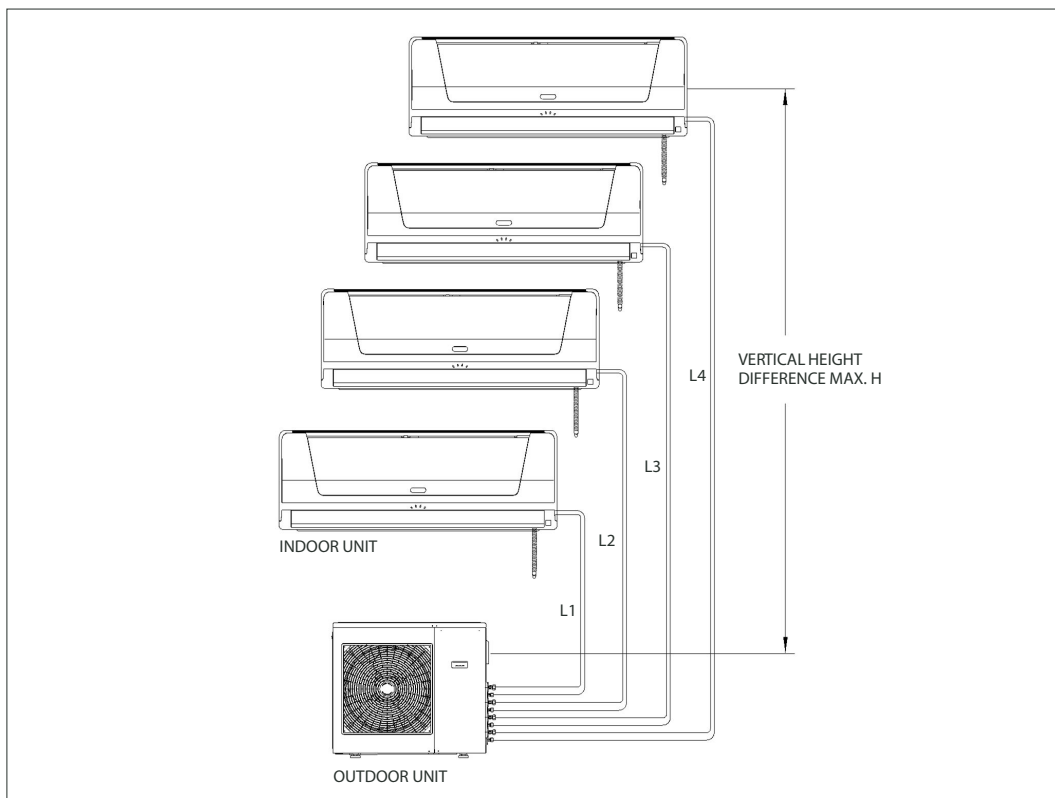

Piping Works

- Do not use contaminated or damaged copper tubing. Do not remove plastic, rubber plugs and brass nuts from the valves, fittings, tubings and coils until you are ready to connect suction or liquid line into valves or fittings.
- If any brazing work is required, ensure that the nitrogen gas passed through coil and joints while the brazing work is being done. This will eliminate soot formation on the inside walls of the copper tubings.
- Cut the connection pipe with a pipe cutter.
- Remove burrs from cut edges of the pipes with remover. Hold the end of the pipe downwards to prevent metal chips from entering the pipe.
- Insert the flare nuts, mounted on the connection parts of both the indoor unit and outdoor unit onto the copper pipes.
- Flare the pipe with extra length above the flaring tool as shown in the table below.
- The flare edge must be even and not cracked or scratched.

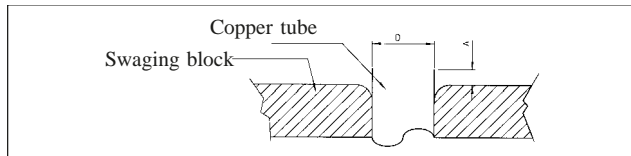

∅ Tube, D		A(mm)	
Inch	mm	Imperial	Rigid
1/4"	6.35	1.3	0.7
3/8"	9.52	1.6	1.0
1/2"	12.70	1.9	1.3
5/8"	15.88	2.2	1.7
3/4"	19.05	2.5	2.0

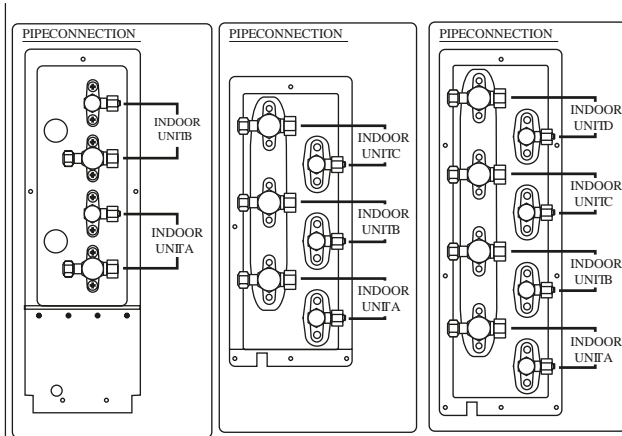

Pos.	M5MSX020A/AR		M5MSX025A/AR		M5MSX030A/AR	
	Liquid	Gas	Liquid	Gas	Liquid	Gas
A	1/4"	3/8"	1/4"	3/8"	1/4"	3/8"
B	1/4"	3/8"	1/4"	3/8"	1/4"	3/8"
C			1/4"	3/8"	1/4"	3/8"
D					1/4"	3/8"

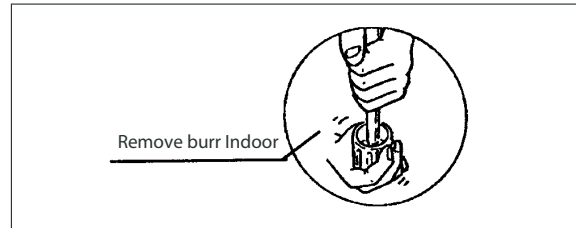
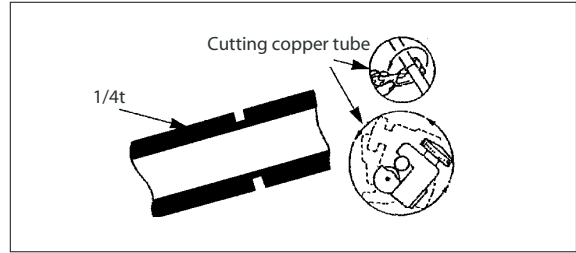

Piping connection to the units

- The outdoor unit is equipped with two to four sets of flare joints depending on O/D unit model. Refer to table below for flare joint size and location.
- In the case where gas pipe from the indoor unit does not match the outdoor flare joints, two different flare joint connectors are provided. The connector should be connected as shown in figure.

No	Flare Joint Connectors
1	3/8" to 1/2" connector
2	1/2" to 3/8" connector

- Align the center of the piping and tighten the flare nut sufficiently with fingers.
- Finally, tighten the flare nut with the torque wrench until the wrench clicks.

Pipe Size mm / (in)	Torque Nm / (ft - lb)
6.35 (1/4)	18 (13.3)
9.53 (3/8)	42 (31.0)
12.70 (1/2)	55 (40.6)

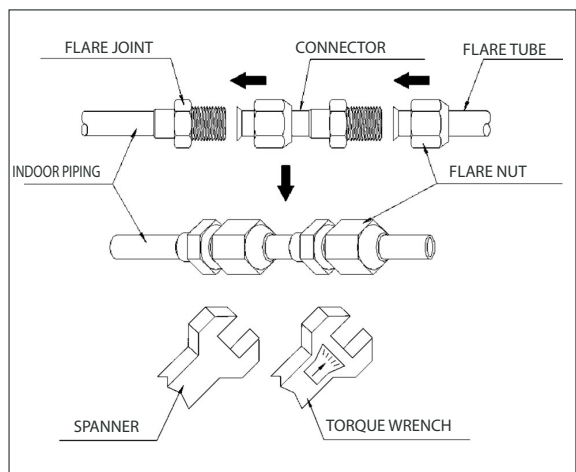

Electrical wiring connection

IMPORTANT : The figures shown in the table are for information purpose only. They should be checked and selected to comply with the local/national codes of regulations. This is also to the type of installation and conductors used.

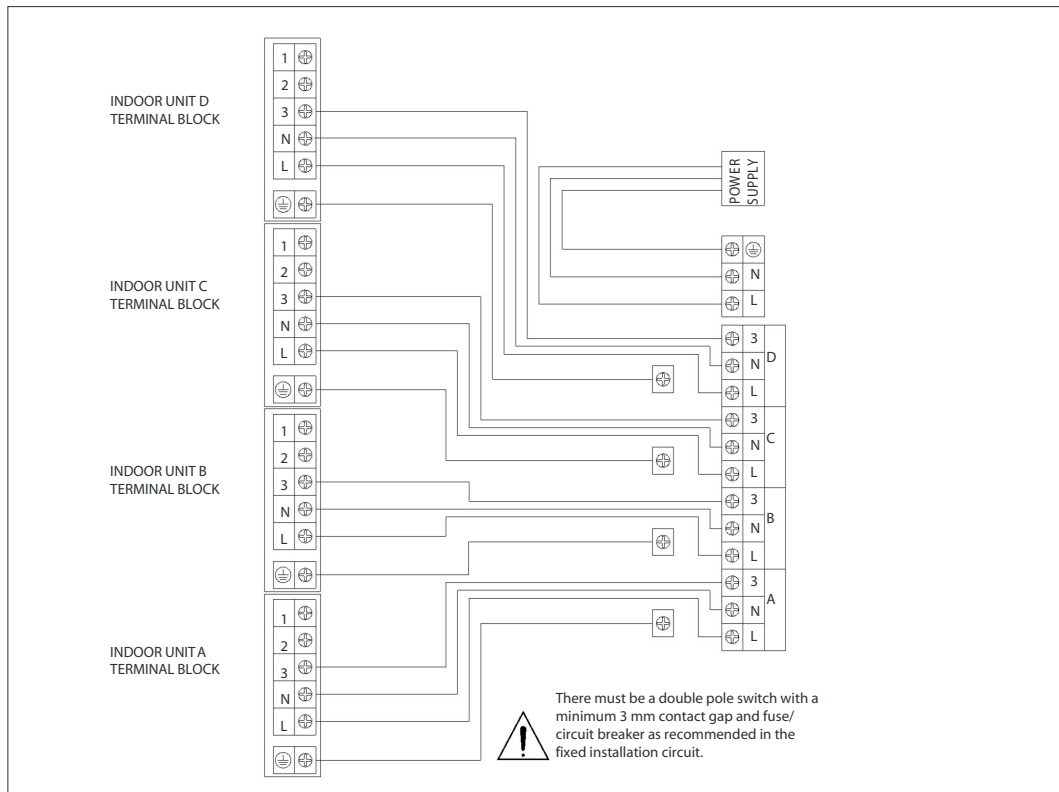

- All wiring must be connected accordingly to the diagram above, with reference to the piping connection. Mismatch any wiring with different piping will cause severe damage to the system.
- All wires must be firmly connected.
- All wires must not touch the refrigerant piping, compressor or any moving parts of the fan motor.
- The connecting wires between the indoor unit and the outdoor unit must be clamped on the wire clamps and the cable tie (push releasable) at the indoor unit and outdoor unit respectively as shown in the figures.
- The power supply cord must be equivalent to H05RN-F (245IEC57) which is the minimum requirement.

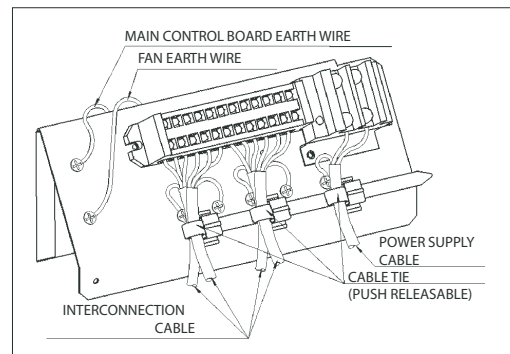

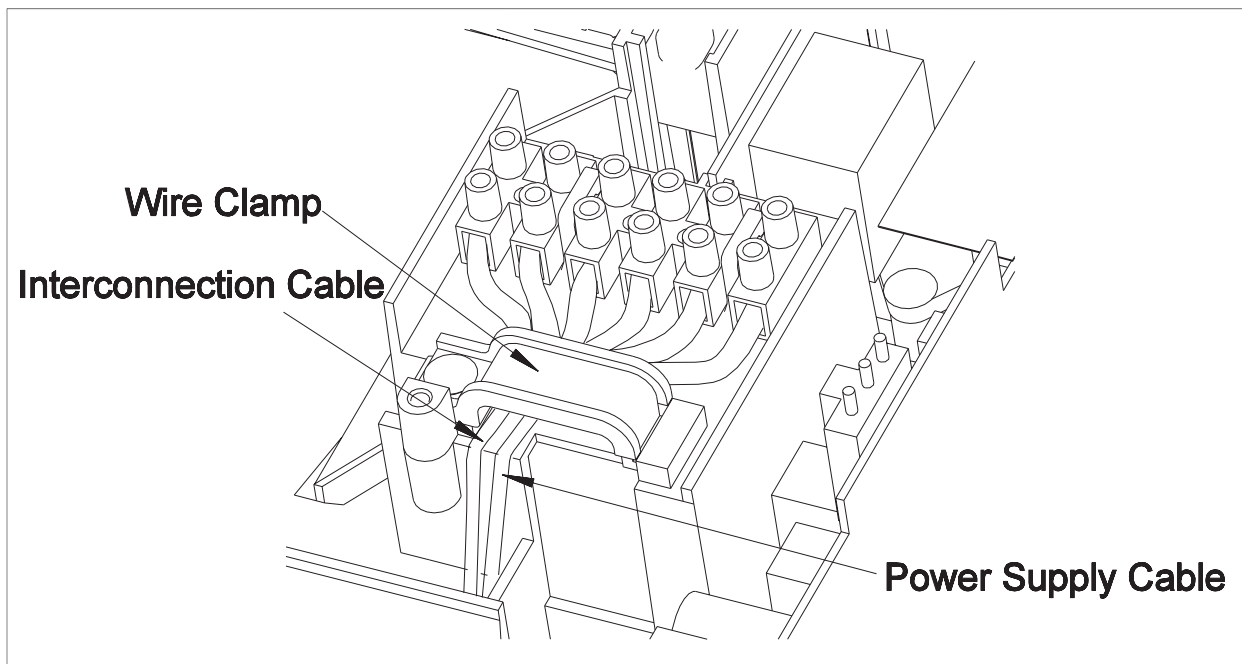

Model	M5WMX010G/15G	M5WMX020G/GR
Voltage range	220V-240V / 1 Ph / 50Hz + ⊕	
Power supply cable size (mm ²)	3.0	
Number of wire	3	
Interconnection cable size (mm ²)	1.5	2.5
Number of wire	4	4
Recommended time delay fuse for O/D unit	25	

- The table above shows the electrical wire sizing for different connection cables. If the length of the cable is more than 2m, use cable with bigger size.
- The figures shown in the table are for information purpose only. They should be checked and selected to comply with the local/national codes of regulations. This is also to the type of installation and conductors used.

Special precautions when dealing with R410A unit

R410A is a new HFC refrigerant which does not damage the ozone layer. The working pressure of this new refrigerant is 1.6 times higher than conventional refrigerant (R22), thus proper installation / servicing is essential.

- Never use refrigerant other than R410A in an air conditioner which designed to operate with R410A.
- POE oil is used as lubricant for R410A compressor, which is different from the mineral oil used for R22 compressor. During installation or servicing, extra precaution must be taken not to expose the R410A system too long to moist air. Residual POE oil in the piping and components can absorb moisture from the air.
- To prevent mischarging, the diameter of the service port on the flare valve is different from that of R22.
- Use tools and materials exclusively for refrigerant R410A. Tools exclusively for R410A are manifold valve, charging hose, pressure gauge, gas leak detector, flare tools, torque wrench, vacuum pump and refrigerant cylinder.
- As an R410A air conditioner incurs higher pressure than R22 units, it is essential to choose the copper pipes correctly. Never use copper pipes thinner than 0.8mm even though they are available in the market.
- If the refrigerant gas leakage occurs during installation / servicing, be sure to ventilate fully. If the refrigerant gas comes into contact with fire, a poisonous gas may occur.
- When installing or removing an air conditioner, do not allow air or moisture to remain in the refrigerant cycle.

Vacuumping and charging

Purging the piping and indoor unit

Except for the outdoor unit which is pre-charged with refrigerant R22, the indoor unit and the refrigerant connection pipes must be air-purged because the air containing moisture that remains in the refrigerant cycle may cause malfunction of the compressor.

- Make sure all pipes are connected securely to the outdoor and indoor valves.
- Remove the caps from the flare valve and the service. Take note that there are a total of two service ports for 5MSX20A/AR, three service ports for 5MSX25A/AR and four service ports for 5MSX30A/AR.
- Connect the center of the charging gauge to the vacuum pump.
- Starting from the bottom 3-way valve (labeled A), connect the charging gauge to the 3-way valve's service port. (The numbers of service ports depend on the O/D unit model).
- Start the vacuum pump. Evacuate for approximately 30 minutes. The evacuation time varies with different vacuum pump capacity. Confirm that the charging gauge needle has moved towards -760mmHg.
- Proceed to the next 3-way valve and repeat the steps above.

Caution

- If the gauge needle does not move to -760mmHg, be sure to check for gas leaks (using the refrigerant detector) at flare type connection of the indoor and outdoor unit and repair the leak before proceeding to the next step.
- Close the valve of the charging gauge and stop the vacuum pump.
- On the outdoor unit, open the suction valve (3 way) and liquid valve (2 way) (in anti-clockwise direction) with 4mm key for hexagon sanded screw.

Additional charge

The refrigerant is pre-charged in the outdoor unit for specific piping length. Please refer to page 1-5 for further detail on additional charge.

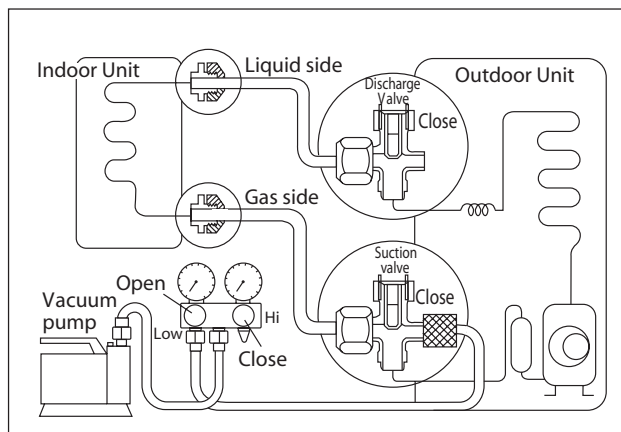
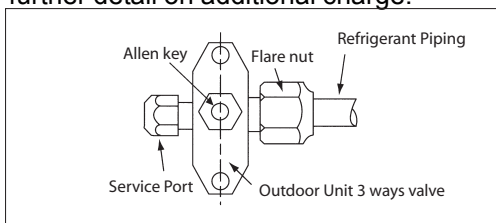

Charge operation

This operation must be done by using a gas cylinder and a precise weighing machine. The additional charge is topped up into the outdoor unit using the suction valve via the service port.

- Remove the service port cap.
- Connect the low pressure side of the charging gauge to the suction service port center of the cylinder tank and close the high pressure side of the gauge. Purge the air from the service hose.
- Start the air conditioner unit.
- Open the gas cylinder and low pressure charging valve.
- When the required refrigerant quantity is pumped into the unit, close the low pressure side and the gas cylinder valve.
- Disconnect the service hose from service port. Put back the service port cap.

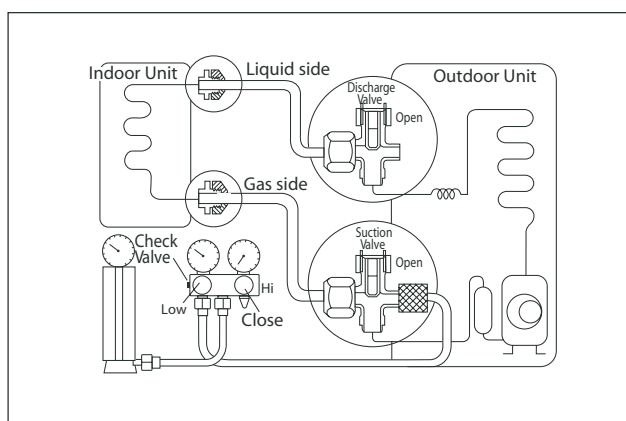

Caution

- R410A must be charged as liquid. Usually R410A cylinder is equipped with a dip-pipe for liquid withdrawal. If there is no dip-pipe, the cylinder should be inverted so as to withdraw liquid R410A from the valve.
- Do not top-up when servicing leak, as this will reduce the unit performance. Vacuum the unit thoroughly and then charge the unit with fresh R410A according to the amount recommended in the specification.

Indicator Lights

IR signal receiver

When an infrared remote control operating signal has been transmitted, the signal receiver on indoor unit will make a (beep) sound to confirm acceptance of the signal transmission. The table shows the LED indicator lights for the indoor air conditioner unit under normal operation and fault conditions. The LED indicator lights are located at the middle of the air conditioner unit for 5WMX-G/GR series.



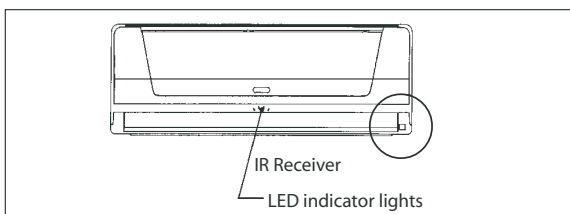

Inverted cooling / Heat pump unit (5WMX-G/GR)

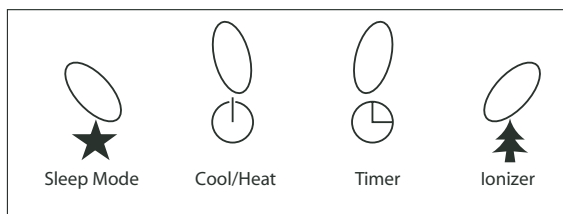

LED indicator lights for cooling unit / Heat pump unit



LED indicator lights : Normal operation and fault conditions for Cooling / Heat pump unit

 SLEEP MODE	 COOL/HEAT	 TIMER	 IONIZER	Normal Operation/ Fault Indication	Action
○ / ●	○ Green		○ / ●	Cooling mode	-
○ / ●	○ Red		○ / ●	Heat mode	-
○ / ●	○ Green/Red			Sleep mode on	-
	○ Green/Red	○ YELLOW		Timer on	-
	○ Green/Red		○ Green	Ionizer on	-
	● Red			Defrost operation	-
	● YELLOW			Indoor temperature sensor / short	Call your dealer
		●		Coil temperature sensor loose / short	Call your dealer
			●	Outdoor temperature sensor loose / short	Call your dealer
●	● Green			Compressor overload protection	Call your dealer
	● YELLOW		●	IPM / PFC error	Call your dealer
		●	●	Outdoor total current trip / DC peak	Call your dealer
●			●	Compressor overheat / Gas leak	Call your dealer
	●	●		Indoor fan feedback error	Call your dealer
●		●		Communication error between indoor and outdoor	Call your dealer
	● Red	●		Anti freeze protection	Call your dealer

○ ON

○ / ● ON or OFF

● BLINK

Air conditioner unit operation

Dry mode

- When the air humidity is high, the unit can operate in dry mode. Press <MODE> button and choose <DRY>.
- If the room temperature is 2°C higher than the set temperature, the air conditioner will operate under cooling mode until it reaches within the 2°C range of difference compared to the set temperature before it converts to dry mode.
- If the room temperature is within the 2°C range of difference compared to the set temperature, it will directly operate under dry mode.
- The indoor fan will operate at super low speed under dry mood.

Heat mode (for heat pump unit only)

- When the unit is switched on from cold start or defrosting cycle, the indoor fan will start to operate only after the coil reaches the desired temperature.
- When compressor stops; the indoor fan will operate until the coil temperature drops to a low level.

Horizontal air flow control

- For more effective air circulation, you can manually adjust the air discharge grille to the left or right.
- During cool mode operation and dry mode operation, do not direct the air discharge louver downwards for too long. If operating continues in this way, condensation may occur on the louver, thus resulting in drippings.

Overheating protection (for heat pump unit only)

- In case the internal and/or the external temperature is too high, or the filter is dirty and clogged up, the refrigerant may be overheated. The compressor will reduce its running speed in order to lower the temperature of heat exchanger. If the temperature is still very high, the compressor will stop.

Standard operating conditions

Cooling unit

Temperature	Ts °C	Th °C
Minimum indoor temperature	19.0	14.0
Maximum indoor temperature	32.0	23.0
Minimum outdoor temperature	19.4	-
Maximum outdoor temperature	46.0	-

Frost prevention

- When the air filter is dirty, the evaporating temperature will decrease and eventually cause frosting.
- When this happens, the compressor will reduce its running speed to prevent freezing. If the coil temperature is still very low, the compressor will stop.

Fan speed and rated cooling capacity

- The rated cooling capacity is provided at the maximum fan speed.
- The cooling capacity is lower when the unit is operating at MEDIUM and LOW speed.

Turbo function

- If higher cooling or heating is required during operation, press "Turbo" button on the remote control to increase the cooling or heating capacity to maximum.
- This function will operate for 15 minutes before it resume to the actual setting.
- The fan noise may be higher if the unit operate in "Turbo" mode.

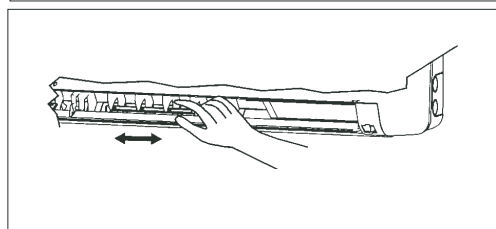
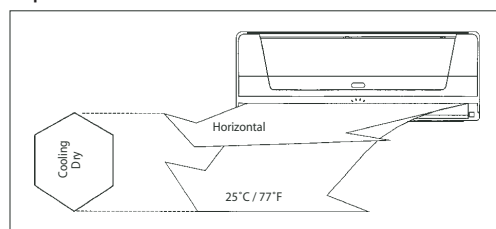

Heat pump unit

Temperature	Ts °C	Th °C
Minimum indoor temperature	16.0	-
Maximum indoor temperature	30.0	-
Minimum outdoor temperature	-8.0	-9.0
Maximum outdoor temperature	24.0	18.0

Ts : Dry bulb temperature

Th: Wet bulb temperature

Electrostatic Filter

Dual Action Electrostatic Air Purifying and Deodorizing Filter Media and Filter Frame

Action 1- Electrostatic air purifying filter

Removes microscopic dust, smoke and small invisible particules to keep the room air clean with pre-charged electrostatic polypropylene filter.

Action 2- Deodorizing filter

Remove unwanted smells and odors in the air and keeps the room air fresh with activated carbon filter.

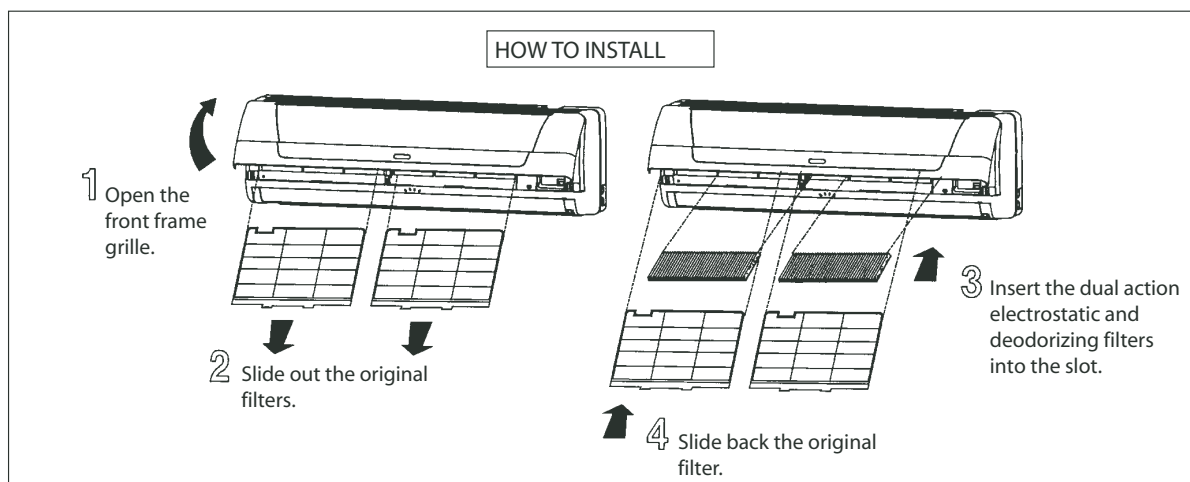

Caution

1. The electrostatic air purifying and deodorizing filter should be replaced once every 6 months or when the filter changes color to brownish, whichever is sooner.
2. Used dusty filters should be disposed and shouldn't be reused, even if it has been cleaned and washed.
3. The filter is a consumable part which you can purchase from your air conditioner dealer.
4. Use the new filter immediately once it has been taken out from its sealed packing. Do not unpack the new filter too early before it is actually used as this may decrease its deodorizing effect.

Engineering and Physical Data

General Data - Cooling Only

MODEL	OUTDOOR UNIT		M5MSX 020A			
	INDOOR UNIT		M5WMX 010G	M5WMX 015G		
NOMINAL COOLING CAPACITY	Btu/h		19000 (4500 - 21000)			
	W		5570 (1320 - 6150)			
NOMINAL TOTAL INPUT POWER	W		1500 (355 - 1870)			
NOMINAL RUNNING CURRENT	A		6.75 (1.61 - 8.42)			
POWER SOURCE	V/Ph/Hz		220 - 240 / 1 / 50			
REFRIGERANT TYPE			R410A			
INDOOR UNIT	CONTROL	AIR DISCHARGE			LOUVER (UP & DOWN) & GRILLE (LEFT & RIGHT)	
		OPERATION			WIRELESS LCD REMOTE CONTROL	
	AIR FLOW	HIGH	CFM / L/s	300 / 141.6	330 / 155.7	
		MEDIUM	CFM / L/s	250 / 118.0	260 / 122.7	
		LOW	CFM / L/s	200 / 94.4	210 / 99.1	
	SOUND PRESSURE (H/M/L)		dBA	39 / 34 / 28	42 / 36 / 29	
	UNIT DIMENSION	HEIGHT	mm/in	260 / 10.2		
		WIDTH	mm/in	899 / 31.5		
		DEPTH	mm/in	198 / 7.8		
	PACKING DIMENSION	HEIGHT	mm/in	337 / 13.3		
		WIDTH	mm/in	957 / 37.7		
		DEPTH	mm/in	270 / 10.6		
	UNIT WEIGHT		kg/lb	9.4		
	CONDENSATE DRAIN SIZE		mm/in	16 / 0.63		
OUTDOOR UNIT	AIR FLOW		CFM / L/s	1300 / 613.5		
	SOUND PRESSURE		dBA	52		
	UNIT DIMENSION	HEIGHT	mm/in	755.5 / 29.7		
		WIDTH	mm/in	940 / 37.0		
		DEPTH	mm/in	392 / 14.3		
	PACKING DIMENSION	HEIGHT	mm/in	790 / 31.1		
		WIDTH	mm/in	1015 / 40.0		
		DEPTH	mm/in	402 / 15.8		
	UNIT WEIGHT		kg/lb	50 / 110.2		
	PIPE CONNECTION	TYPE			FLARE	
		SIZE	LIQUID	mm/in	2 x (6.35 / 1/4")	
			GAS	mm/in	2 x (9.52 / 3/8")	
	REFRIGERANT CHARGE		kg/lb	1.65 / 3.64		

1) ALL SPECIFICATIONS ARE SUBJECTED TO CHANGE BY THE MANUFACTURER WITHOUT PRIOR NOTICE.

2) ALL UNITS ARE BEING TESTED AND COMPLY TO ISO 5151.

3) NOMINAL COOLING IS BASED ON THE CONDITIONS BELOW:

a) COOLING - 27°C DB / 19°C WB INDOOR AND 35°C DB / 24°C WB OUTDOOR

4) SOUND PRESSURE LEVEL ARE ACCORDING TO JIS B 8615 STANDARD. POSITION OF THE MEASUREMENT POINT IS 1m IN FRONT AND 1m BELOW THE UNIT.

General Data - Cooling Only

MODEL	OUTDOOR UNIT		M5MSX 025A		
	INDOOR UNIT		M5WMX 010G	M5WMX 015G	
NOMINAL COOLING CAPACITY	Btu/h		22000 (9000 - 24000)		
	W		6450 (2640 - 7030)		
NOMINAL TOTAL INPUT POWER	W		1815 (590 - 2200)		
NOMINAL RUNNING CURRENT	A		8.13 (3.18 - 9.86)		
POWER SOURCE	V/Ph/Hz		220 - 240 / 1 / 50		
REFRIGERANT TYPE	R410A				
INDOOR UNIT	CONTROL	AIR DISCHARGE OPERATION		DOUBLE LOUVER (UP & DOWN) & GRILLE (LEFT & RIGHT)	
		LCD WIRELESS REMOTE CONTROL			
	AIR FLOW	HIGH	CFM / l/s	300 / 141.6	330 / 155.7
		MEDIUM	CFM / l/s	250 / 118.0	260 / 122.7
		LOW	CFM / l/s	200 / 94.4	210 / 99.1
	SOUND PRESSURE (H/M/L)	dBA		39 / 34 / 28	42 / 36 / 29
	UNIT DIMENSION	HEIGHT	mm/in	260 / 10.2	
		WIDTH	mm/in	899 / 31.5	
		DEPTH	mm/in	198 / 7.8	
	PACKING DIMENSION	HEIGHT	mm/in	337 / 13.3	
		WIDTH	mm/in	957 / 37.7	
		DEPTH	mm/in	270 / 10.6	
	UNIT WEIGHT	kg/lb		9.4 / 20.73	
	CONDENSATE DRAIN SIZE	mm/in		16 / 0.63	
OUTDOOR UNIT	AIR FLOW	CFM / l/s		1600 / 755.2	
	SOUND PRESSURE	dBA		53	
	UNIT DIMENSION	HEIGHT	mm/in	757 / 29.8	
		WIDTH	mm/in	940 / 37.0	
		DEPTH	mm/in	392 / 14.3	
	PACKING DIMENSION	HEIGHT	mm/in	790 / 31.1	
		WIDTH	mm/in	1015 / 40.0	
		DEPTH	mm/in	402 / 15.8	
	UNIT WEIGHT	kg/lb		60 / 132.3	
	PIPE CONNECTION	TYPE		FLARE	
SIZE		LIQUID	mm/in	2 x (6.35 / ¼")	
		GAS	mm/in	2 x (9.52 / 3/8")	
REFRIGERANT CHARGE	kg/lb		2.32 / 5.1		

1) ALL SPECIFICATIONS ARE SUBJECTED TO CHANGE BY THE MANUFACTURER WITHOUT PRIOR NOTICE.

2) ALL UNITS ARE BEING TESTED AND COMPLY TO ISO 5151.

3) NOMINAL COOLING IS BASED ON THE CONDITIONS BELOW :

a) COOLING - 27°C DB / 19°C WB INDOOR AND 35°C DB / 24°C WB OUTDOOR

4) SOUND PRESSURE LEVEL ARE ACCORDING TO JIS B 8615 STANDARD. POSITION OF THE MEASUREMENT POINT IS 1m IN FRONT AND 1m BELOW THE UNIT.

General Data - Cooling Only

MODEL	OUTDOOR UNIT		M5MSX 025A	
	INDOOR UNIT		M5WMX 020G	
NOMINAL COOLING CAPACITY	Btu/h		22000 (9000 - 24000)	
	W		6450 (2640 - 7030)	
NOMINAL TOTAL INPUT POWER	W		1815 (590 - 2200)	
NOMINAL RUNNING CURRENT	A		8.13 (3.18 - 9.86)	
POWER SOURCE	V/Ph/Hz		220 - 240 / 1 / 50	
REFRIGERANT TYPE			R410A	
INDOOR UNIT	CONTROL	AIR DISCHARGE OPERATION		DOUBLE LOUVER (UP & DOWN) & GRILLE (LEFT & RIGHT)
				LCD WIRELESS REMOTE CONTROL
	AIR FLOW	HIGH	CFM / l/s	550 / 236.0
		MEDIUM	CFM / l/s	440 / 207.7
		LOW	CFM / l/s	370 / 174.6
	SOUND PRESSURE (H/M/L)		dBA	44 / 40 / 35
	UNIT DIMENSION	HEIGHT	mm/in	304 / 12.0
		WIDTH	mm/in	1062 / 41.8
		DEPTH	mm/in	220 / 8.7
	PACKING DIMENSION	HEIGHT	mm/in	378 / 14.9
		WIDTH	mm/in	1130 / 44.5
		DEPTH	mm/in	292 / 11.5
	UNIT WEIGHT		kg/lb	15 / 33.1
	CONDENSATE DRAIN SIZE		mm/in	20 / 0.79
OUTDOOR UNIT	AIR FLOW		CFM / l/s	1600 / 755.2
	SOUND PRESSURE		dBA	53
	UNIT DIMENSION	HEIGHT	mm/in	757 / 29.8
		WIDTH	mm/in	940 / 37.0
		DEPTH	mm/in	392 / 14.3
	PACKING DIMENSION	HEIGHT	mm/in	790 / 31.1
		WIDTH	mm/in	1015 / 40.0
		DEPTH	mm/in	402 / 15.8
	UNIT WEIGHT		kg/lb	60 / 132.3
	PIPE CONNECTION	TYPE		FLARE
		SIZE	LIQUID	mm/in
GAS			mm/in	2 x (9.52 / 3/8")
REFRIGERANT CHARGE		kg/lb	2.32 / 5.1	

1) ALL SPECIFICATIONS ARE SUBJECTED TO CHANGE BY THE MANUFACTURER WITHOUT PRIOR NOTICE.

2) ALL UNITS ARE BEING TESTED AND COMPLY TO ISO 5151.

3) NOMINAL COOLING IS BASED ON THE CONDITIONS BELOW :

a) COOLING - 27°C DB / 19°C WB INDOOR AND 35°C DB / 24°C WB OUTDOOR

4) SOUND PRESSURE LEVEL ARE ACCORDING TO JIS B 8615 STANDARD. POSITION OF THE MEASUREMENT POINT IS 1m IN FRONT AND 1m BELOW THE UNIT.

General Data - Cooling Only

MODEL	OUTDOOR UNIT		M5MSX030A			
	INDOOR UNIT		M5WMX010G	M5WMX015G	M5WMX020G	
NOMINAL COOLING CAPACITY		Btu/h	26000 (4500 - 29000)			
		W	7620 (1320 - 8500)			
NOMINAL TOTAL INPUT POWER		W	2350 (400 - 2815)			
NOMINAL RUNNING CURRENT		A	10.44 (1.81 - 12.50)			
POWER SOURCE		V/Ph/Hz	220 - 240 / 1 / 50			
REFRIGERANT TYPE			R410A			
INDOOR UNIT	CONTROL		DOUBLE LOUVER (UP & DOWN) & GRILLE (LEFT & RIGHT)			
			LCD WIRELESS REMOTE CONTROL			
	AIR FLOW	HIGH	CFM / l/s	300 / 142	330 / 157	550 / 261
		MEDIUM	CFM / l/s	250 / 118	260 / 123	440 / 208
		LOW	CFM / l/s	200 / 95	210 / 100	370 / 176
	SOUND PRESSURE (H/M/L)		dBA	39 / 34 / 28	42 / 36 / 29	44 / 40 / 35
	UNIT DIMENSION	HEIGHT	mm/in	260 / 10.2		304 / 12.0
		WIDTH	mm/in	899 / 31.5		1062 / 41.8
		DEPTH	mm/in	198 / 7.8		220 / 8.7
	PACKING DIMENSION	HEIGHT	mm/in	337 / 13.3		378 / 14.9
		WIDTH	mm/in	957 / 37.7		1130 / 44.5
		DEPTH	mm/in	270 / 10.6		292 / 11.5
	UNIT WEIGHT		kg/lb	9.4 / 20.7		15 / 33.1
CONDENSATE DRAIN SIZE		mm/in	16 / 0.63		20 / 0.79	
OUTDOOR UNIT	AIR FLOW		CFM / l/s	1600 / 755.2		
	SOUND PRESSURE		dBA	56		
	UNIT DIMENSION	HEIGHT	mm/in	757 / 29.8		
		WIDTH	mm/in	940 / 37.0		
		DEPTH	mm/in	392 / 14.3		
	PACKING DIMENSION	HEIGHT	mm/in	793 / 31.3		
		WIDTH	mm/in	985 / 38.8		
		DEPTH	mm/in	410 / 16.2		
	UNIT WEIGHT		kg/lb	72 / 158.7		
	PIPE CONNECTION	TYPE		FLARE		
SIZE		LIQUID	mm/in	4 x (6.35 / 1/4")		
		GAS	mm/in	4 x (9.52 / 3/8")		
REFRIGERANT CHARGE		kg/lb	3.39 / 7.45			

1) ALL SPECIFICATIONS ARE SUBJECTED TO CHANGE BY THE MANUFACTURER WITHOUT PRIOR NOTICE.

2) ALL UNITS ARE BEING TESTED AND COMPLY TO ISO 5151.

3) NOMINAL COOLING IS BASED ON THE CONDITIONS BELOW :

a) COOLING - 27°C DB / 19°C WB INDOOR AND 35°C DB / 24°C WB OUTDOOR

4) SOUND PRESSURE LEVEL ARE ACCORDING TO JIS B 8615 STANDARD. POSITION OF THE MEASUREMENT POINT IS 1m IN FRONT AND 1m BELOW THE UNIT.

General Data - Heatpump

MODEL	OUTDOOR UNIT		M5MSX 020AR		
	INDOOR UNIT		M5WMX 010GR	M5WMX 015GR	
NOMINAL COOLING CAPACITY	Btu/h		19000 (4500 - 21000)		
	W		5570 (1320 - 6150)		
NOMINAL HEATING CAPACITY	Btu/h		21000 (4500 - 23000)		
	W		6150 (1320 - 6740)		
NOMINAL TOTAL INPUT POWER (COOLING)	W		1500 (355 - 1870)		
NOMINAL TOTAL INPUT POWER (HEATING)	W		1630 (350 - 1950)		
NOMINAL RUNNING CURRENT (COOLING)	A		6.75 (1.61 - 8.42)		
NOMINAL RUNNING CURRENT (HEATING)	A		7.38 (1.59 - 8.83)		
POWER SOURCE	V/Ph/Hz		220 - 240 / 1 / 50		
REFRIGERANT TYPE			R410A		
INDOOR UNIT	CONTROL	AIR DISCHARGE		LOUVER (UP & DOWN) & GRILLE (LEFT & RIGHT)	
		OPERATION		WIRELESS LCD REMOTE CONTROL	
	AIR FLOW	HIGH	CFM / L/s	300 / 141.6	330 / 155.7
		MEDIUM	CFM / L/s	250 / 118.0	260 / 122.7
		LOW	CFM / L/s	200 / 94.4	210 / 99.1
	SOUND PRESSURE (H/M/L)		dBA	39 / 34 / 28	42 / 36 / 29
	UNIT DIMENSION	HEIGHT	mm/in	260 / 10.2	
		WIDTH	mm/in	899 / 31.5	
		DEPTH	mm/in	198 / 7.8	
	PACKING DIMENSION	HEIGHT	mm/in	337 / 13.3	
		WIDTH	mm/in	957 / 37.7	
		DEPTH	mm/in	270 / 10.6	
	UNIT WEIGHT		kg/lb	9.4	
	CONDENSATE DRAIN SIZE		mm/in	16 / 0.63	
AIR FLOW		CFM / L/s	1300 / 613.5		
SOUND PRESSURE		dBA	52		
UNIT DIMENSION	HEIGHT	mm/in	755.5 / 29.7		
	WIDTH	mm/in	940 / 37.0		
	DEPTH	mm/in	392 / 14.3		
PACKING DIMENSION	HEIGHT	mm/in	790 / 31.1		
	WIDTH	mm/in	1015 / 40.0		
	DEPTH	mm/in	402 / 15.8		
UNIT WEIGHT		kg/lb	50 / 110.2		
PIPE CONNECTION	TYPE		FLARE		
	SIZE	LIQUID	mm/in	2 x (6.35 / ¼")	
		GAS	mm/in	2 x (9.52 / 3/8")	
REFRIGERANT CHARGE		kg/lb	1.65 / 3.64		

1) ALL SPECIFICATIONS ARE SUBJECTED TO CHANGE BY THE MANUFACTURER WITHOUT PRIOR NOTICE.

2) ALL UNITS ARE BEING TESTED AND COMPLY TO ISO 5151.

3) NOMINAL COOLING AND HEATING CAPACITY ARE BASED ON THE CONDITIONS BELOW :

a) COOLING - 27°C DB / 19°C WB INDOOR AND 35°C DB / 24°C WB OUTDOOR

b) HEATING - 20°C DB INDOOR AND 7°C DB / 6°C WB OUTDOOR

4) SOUND PRESSURE LEVEL ARE ACCORDING TO JIS B 8615 STANDARD. POSITION OF THE MEASUREMENT POINT IS 1m IN FRONT AND 1m BELOW THE UNIT.

General Data - Heatpump

MODEL	OUTDOOR UNIT		M5MSX 025AR		
	INDOOR UNIT		M5WMX 010GR	M5WMX 015GR	
NOMINAL COOLING CAPACITY	Btu/h		22000 (9000 - 24000)		
	W		6450 (2640 - 7030)		
NOMINAL HEATING CAPACITY	Btu/h		25000 (4500 - 26000)		
	W		7330 (1320 - 7620)		
NOMINAL TOTAL INPUT POWER (COOLING)	W		1815 (590 - 2200)		
NOMINAL TOTAL INPUT POWER (HEATING)	W		1900 (400 - 2155)		
NOMINAL RUNNING CURRENT (COOLING)	A		8.13 (3.18 - 9.86)		
NOMINAL RUNNING CURRENT (HEATING)	A		8.52 (1.81 - 9.57)		
POWER SOURCE	V/Ph/Hz		220 - 240 / 1 /50		
REFRIGERANT TYPE			R410A		
INDOOR UNIT	CONTROL	AIR DISCHARGE			DOUBLE LOUVER (UP & DOWN) & GRILLE (LEFT & RIGHT)
		OPERATION			LCD WIRELESS REMOTE CONTROL
	AIR FLOW	HEIGHT	CFM / l/s	300 / 141.6	330 / 155.7
		MEDIUM	CFM / l/s	250 / 118.0	260 / 122.7
		LOW	CFM / l/s	200 / 94.4	210 / 99.1
	SOUND PRESSURE (H/M/L)		dBA	39 / 34 / 28	42 / 36 / 29
	UNIT DIMENSION	HEIGHT	mm/in	260 / 10.2	
		WIDTH	mm/in	899 / 31.5	
		DEPTH	mm/in	198 / 7.8	
	PACKING DIMENSION	HEIGHT	mm/in	337 / 13.3	
		WIDTH	mm/in	957 / 37.7	
		DEPTH	mm/in	270 / 10.6	
	UNIT WEIGHT		kg/lb	9.4 / 20.73	
	CONDENSATE DRAIN SIZE		mm/in	16 / 0.63	
AIR FLOW		CFM / l/s	1600 / 755.2		
SOUND PRESSURE		dBA	53		
UNIT DIMENSION	HEIGHT	mm/in	757 / 29.8		
	WIDTH	mm/in	940 / 37.0		
	DEPTH	mm/in	392 / 14.3		
PACKING DIMENSION	HEIGHT	mm/in	790 / 31.1		
	WIDTH	mm/in	1015 / 40.0		
	DEPTH	mm/in	402 / 15.8		
UNIT WEIGHT		kg/lb	60 / 132.3		
PIPE CONNECTION	TYPE			FLARE	
	SIZE	LIQUID	mm/in	2 x (6.35 / 1/4")	
		GAS	mm/in	2 x (9.52 / 3/8")	
REFRIGERANT CHARGE		kg/lb	2.32 / 5.1		

1) ALL SPECIFICATIONS ARE SUBJECTED TO CHANGE BY THE MANUFACTURER WITHOUT PRIOR NOTICE.

2) ALL UNITS ARE BEING TESTED AND COMPLY TO ISO 5151.

3) NOMINAL COOLING AND HEATING CAPACITY ARE BASED ON THE CONDITIONS BELOW :

a) COOLING - 27°C DB / 19°C WB INDOOR AND 35°C DB / 24°C WB OUTDOOR

b) HEATING - 20°C DB INDOOR AND 7°C DB / 6°C WB OUTDOOR

4) SOUND PRESSURE LEVEL ARE ACCORDING TO JIS B 8615 STANDARD. POSITION OF THE MEASUREMENT POINT IS 1m IN FRONT AND 1m BELOW THE UNIT.

General Data - Heatpump

MODEL		OUTDOOR UNIT		M5MSX 025AR			
		INDOOR UNIT		M5WMX 020GR			
NOMINAL COOLING CAPACITY		Btu/h		22000 (9000 - 24000)			
		W		6450 (2640 - 7030)			
NOMINAL HEATING CAPACITY		Btu/h		25000 (4500 - 26000)			
		W		7330 (1320 - 7620)			
NOMINAL TOTAL INPUT POWER (COOLING)		W		1815 (590 - 2200)			
NOMINAL TOTAL INPUT POWER (HEATING)		W		1900 (400 - 2155)			
NOMINAL RUNNING CURRENT (COOLING)		A		8.13 (3.18 - 9.86)			
NOMINAL RUNNING CURRENT (HEATING)		A		8.52 (1.81 - 9.57)			
POWER SOURCE		V/Ph/Hz		220 - 240 / 1 / 50			
REFRIGERANT TYPE				R410A			
INDOOR UNIT	CONTROL		AIR DISCHARGE		DOUBLE LOUVER (UP & DOWN) & GRILLE (LEFT & RIGHT)		
			OPERATION		LCD WIRELESS REMOTE CONTROL		
	AIR FLOW		HIGH		CFM / l/s		
			MEDIUM		CFM / l/s		
			LOW		CFM / l/s		
	SOUND PRESSURE (H/M/L)		dBA		44 / 40 / 35		
	UNIT DIMENSION		HEIGHT		mm/in		
			WIDTH		mm/in		
			DEPTH		mm/in		
	PACKING DIMENSION		HEIGHT		mm/in		
			WIDTH		mm/in		
			DEPTH		mm/in		
UNIT WEIGHT		kg/lb		15 / 33.1			
CONDENSATE DRAIN SIZE		mm/in		20 / 0.79			
OUTDOOR UNIT	AIR FLOW		CFM / l/s		1600 / 755.2		
	SOUND PRESSURE		dBA		53		
	UNIT DIMENSION		HEIGHT		mm/in		
			WIDTH		mm/in		
			DEPTH		mm/in		
	PACKING DIMENSION		HEIGHT		mm/in		
			WIDTH		mm/in		
			DEPTH		mm/in		
	UNIT WEIGHT		kg/lb		60 / 132.3		
	PIPE CONNECTION		TYPE		FLARE		
			SIZE		LIQUID		mm/in
GAS					mm/in		
REFRIGERANT CHARGE		kg/lb		2.32 / 5.1			

1) ALL SPECIFICATIONS ARE SUBJECTED TO CHANGE BY THE MANUFACTURER WITHOUT PRIOR NOTICE.

2) ALL UNITS ARE BEING TESTED AND COMPLY TO ISO 5151.

3) NOMINAL COOLING AND HEATING CAPACITY ARE BASED ON THE CONDITIONS BELOW :

a) COOLING - 27°C DB / 19°C WB INDOOR AND 35°C DB / 24°C WB OUTDOOR

b) HEATING - 20°C DB INDOOR AND 7°C DB / 6°C WB OUTDOOR

4) SOUND PRESSURE LEVEL ARE ACCORDING TO JIS B 8615 STANDARD. POSITION OF THE MEASUREMENT POINT IS 1m IN FRONT AND 1m BELOW THE UNIT.

General Data - Heatpump

MODEL	OUTDOOR UNIT		M5MSX 030AR			
	INDOOR UNIT		M5WMX 010GR	M5WMX 015GR	M5WMX 020GR	
NOMINAL COOLING CAPACITY	Btu/h		26000 (4500 - 29000)			
	W		7620 (1320 - 8500)			
NOMINAL HEATING CAPACITY	Btu/h		28000 (4500 - 32000)			
	W		8210 (1320 - 9380)			
NOMINAL TOTAL INPUT POWER (COOLING)	W		2350 (400 - 2815)			
NOMINAL TOTAL INPUT POWER (HEATING)	W		2030 (400 - 2755)			
NOMINAL RUNNING CURRENT (COOLING)	A		10.44 (1.81 - 12.50)			
NOMINAL RUNNING CURRENT (HEATING)	A		9.0 (1.81 - 12.22)			
POWER SOURCE	V/Ph/Hz		220 - 240 / 1 / 50			
REFRIGERANT TYPE			R410A			
INDOOR UNIT	CONTROL	AIR DISCHARGE		DOUBLE LOUVER (UP & DOWN) & GRILLE (LEFT & RIGHT)		
		OPERATION		LCD WIRELESS REMOTE CONTROL		
	AIR FLOW	HIGH	CFM / l/s	300 / 142	330 / 157	550 / 261
		MEDIUM	CFM / l/s	250 / 118	260 / 123	440 / 208
		LOW	CFM / l/s	200 / 95	210 / 100	370 / 176
	SOUND PRESSURE (H/M/L)		dB(A)	39 / 34 / 28	42 / 36 / 29	44 / 40 / 35
	UNIT DIMENSION	HEIGHT	mm/in	260 / 10.2		304 / 12.0
		WIDTH	mm/in	899 / 31.5		1062 / 41.8
		DEPTH	mm/in	198 / 7.8		220 / 8.7
	PACKING DIMENSION	HEIGHT	mm/in	337 / 13.3		378 / 14.9
		WIDTH	mm/in	957 / 37.7		1130 / 44.5
		DEPTH	mm/in	270 / 10.6		292 / 11.5
	UNIT WEIGHT		kg/lb	9.4 / 20.7		15 / 33.1
	CONDENSATE DRAIN SIZE		mm/in	16 / 0.63		20 / 0.79
OUTDOOR UNIT	AIR FLOW		CFM / l/s	1600 / 755.2		
	SOUND PRESSURE		dB(A)	56		
	UNIT DIMENSION	HEIGHT	mm/in	757 / 29.8		
		WIDTH	mm/in	940 / 37.0		
		DEPTH	mm/in	392 / 14.3		
	PACKING DIMENSION	HEIGHT	mm/in	793 / 31.3		
		WIDTH	mm/in	985 / 38.8		
		DEPTH	mm/in	410 / 16.2		
	UNIT WEIGHT		kg/lb	72 / 158.7		
	PIPE CONNECTION	TYPE		FLARE		
		SIZE	LIQUID	mm/in	4 x (6.35 / 1/4")	
GAS			mm/in	4 x (9.52 / 3/8")		
REFRIGERANT CHARGE		kg/lb	3.39 / 7.45			

1) ALL SPECIFICATIONS ARE SUBJECTED TO CHANGE BY THE MANUFACTURER WITHOUT PRIOR NOTICE.

2) ALL UNITS ARE BEING TESTED AND COMPLY TO ISO 5151.

3) NOMINAL COOLING AND HEATING CAPACITY ARE BASED ON THE CONDITIONS BELOW :

a) COOLING - 27°C DB / 19°C WB INDOOR AND 35°C DB / 24°C WB OUTDOOR

b) HEATING - 20°C DB INDOOR AND 7°C DB / 6°C WB OUTDOOR

4) SOUND PRESSURE LEVEL ARE ACCORDING TO JIS B 8615 STANDARD. POSITION OF THE MEASUREMENT POINT IS 1m IN FRONT AND 1m BELOW THE UNIT.

Components Data

MODEL	OUTDOOR UNIT		M5MSX 020A	
	INDOOR UNIT		M5WMX 010GR	M5WMX 015G
INDOOR FAN	TYPE		ANTI FUNGUS CROSS FLOW FAN	
	QUANTITY		1	1
	MATERIAL		ACRYLO NITRILE STYRENE	
	DRIVE		DIRECT	
	DIAMETER	mm/in	87 / 3.4	
	LENGTH	mm/in	636 / 25.0	
INDOOR FAN MOTOR	TYPE		INDUCTION	
	Q'TY		1	
	INDEX OF PROTECTION (IP)		IP24	
OUTDOOR FAN	TYPE		PROPELLER FAN	
	QUANTITY		1	
	MATERIAL		GLASS REINFORCED ACRYL STYRENE RESIN	
	DIAMETER	mm/in	460 / 18.11	
OUTDOOR FAN MOTOR	TYPE		INDUCTION	
	QUANTITY		1	
	INDEX OF PROTECTION (IP)		IP24	
COMPRESSOR	TYPE		DC BRUSHLESS SCROLL	
	OIL TYPE		POLYOESTER OIL (POE)	
	OIL AMOUNT	cm ³ / fl.oz	480 / 16.23	
INDOOR COIL	TUBE	MATERIAL	INNER GROOVED SEAMLESS COPPER TUBE	
		DIAMETER	mm/in	7.0 / 0.276
		THICKNESS	mm/in	0.28 / 0.011
	FIN	MATERIAL	ALUMINIUM (HYDROPHILIC SLIT FIN TYPE)	
		THICKNESS	mm/in	0.11 / 0.0043
		FACE AREA	m ² /ft ²	0.193 / 2.08
		ROW		2
		FIN PER INCH		18
OUTDOOR COIL	TUBE	MATERIAL	INNER GROOVED SEAMLESS COPPER TUBE	
		DIAMETER	mm/in	7.0 / 0.276
		THICKNESS	mm/in	0.32 / 0.013
	FIN	MATERIAL	ALUMINIUM (HYDROPHILIC SLIT FIN TYPE)	
		THICKNESS	mm/in	0.11 / 0.0043
		FACE AREA	m ² /ft ²	0.62 / 6.67
		ROW		2
		FIN PER INCH		20
FILTRATION	TYPE		SARANET	
	QUANTITY	pc	2	
	DIMENSION (L x W x t)	mm/in	386 x 364.3 x 1.5 / 15.2 x 14.3 x 0.06	
	TYPE		ANTI-MICROBIAL	
	QUANTITY	pc	1	
	DIMENSION (L x W x t)	mm/in	248 x 43 x 5 / 9.8 x 1.7 x 0.2	
	TYPE		TITANIUM OXIDE	
	QUANTITY	pc	1	
	DIMENSION (L x W x t)	mm/in	248 x 43 x 5 / 9.8 x 1.7 x 0.2	
CASING	INDOOR UNIT	MATERIAL	HIGH IMPACT POLYSTYRENE	
		COLOUR	LIGHT GREY	
	OUTDOOR UNIT	MATERIAL	GALVANISED MILD STEEL	
		COLOUR	LIGHT GREY	

1) ALL SPECIFICATION ARE SUBJECTED TO CHANGE BY THE MANUFACTURER WITHOUT PRIOR NOTICE

Components Data

MODEL	OUTDOOR UNIT		M5MSX 025A	
	INDOOR UNIT		M5WMX 010G	M5WMX 015G
INDOOR FAN	TYPE		ANTI FUNGUS CROSS FLOW FAN	
	QUANTITY		1	1
	MATERIAL		ACRYLO NITRILE STYRENE	
	DRIVE		DIRECT	
	DIAMETER	mm/in	87 / 3.4	
	LENGTH	mm/in	636 / 25.0	
INDOOR FAN MOTOR	TYPE		INDUCTION	
	QTY		1	
	INDEX OF PROTECTION (IP)		IP24	
OUTDOOR FAN	TYPE		PROPELLER	
	QUANTITY		1	
	MATERIAL		GLASS REINFORCED ACRLY STYRENE RESIN	
	DIAMETER	mm/in	460 / 18	
OUTDOOR FAN MOTOR	TYPE		INDUCTION	
	QUANTITY		1	
	INDEX OF PROTECTION (IP)		IP24	
COMPRESSOR	TYPE		DC INVERTER TWIN ROTARY	
	OIL TYPE		POLYVINYLEETHER OIL (PVE)	
	OIL AMOUNT	cm ³ / fl.oz	800 / 27.05	
INDOOR COIL	TUBE	MATERIAL	INNER GROOVED SEAMLESS COPPER TUBE	
		DIAMETER	mm/in	7.0 / 0.276
		THICKNESS	mm/in	0.28 / 0.011
	FIN	MATERIAL	ALUMINIUM (HYDROPHILIC SLIT FIN TYPE)	
		THICKNESS	mm/in	0.11 / 0.0043
		FACE AREA	m ² /ft ²	0.193 / 2.08
		ROW	2	
FIN PER INCH		18		
OUTDOOR COIL	TUBE	MATERIAL	INNER GROOVED SEAMLESS COPPER TUBE	
		DIAMETER	mm/in	7.0 / 0.276
		THICKNESS	mm/in	0.32 / 0.013
	FIN	MATERIAL	ALUMINIUM (HYDROPHILIC SLIT FIN TYPE)	
		THICKNESS	mm/in	0.11 / 0.0043
		FACE AREA	m ² /ft ²	0.62 / 6.67
		ROW	2	
FIN PER INCH		20		
FILTRATION	TYPE		SARANET	
	QUANTITY	pc	2	
	DIMENSION (L x W x t)		386 x 364.3 x 1.5 / 15.2 x 14.3 x 0.06	
	TYPE		ANTI-MICROBIAL	
	QUANTITY	pc	1	
	DIMENSION (L x W x t)		248 x 43 x 5 / 9.8 x 1.7 x 0.2	
	TYPE		TITANIUM OXIDE	
	QUANTITY	pc	1	
DIMENSION (L x W x t)		248 x 43 x 5 / 9.8 x 1.7 x 0.2		
CASING	INDOOR UNIT	MATERIAL	HIGH IMPACT POLYSTYRENE	
		COLOUR	LIGHT GREY	
	OUTDOOR UNIT	MATERIAL	GALVANISED MILD STEEL	
		COLOUR	LIGHT GREY	

1) ALL SPECIFICATION ARE SUBJECTED TO CHANGE BY THE MANUFACTURER WITHOUT PRIOR NOTICE

Components Data

MODEL	OUTDOOR UNIT		M5MSX 025A	
	INDOOR UNIT		M5WMX 020G	
INDOOR FAN	TYPE		ANTI FUNGUS CROSS FLOW FAN	
	QUANTITY		1	
	MATERIAL		ACRYLO NITRILE STYRENE	
	DRIVE		DIRECT	
	DIAMETER	mm/in	87 / 3.4	
	LENGTH	mm/in	636 / 25.0	
INDOOR FAN MOTOR	TYPE		INDUCTION	
	Q'TY		1	
	INDEX OF PROTECTION (IP)		IP24	
OUTDOOR FAN	TYPE		PROPELLER	
	QUANTITY		1	
	MATERIAL		GLASS REINFORCED ACRYL STYRENE RESIN	
	DRIVE		DIRECT	
	DIAMETER	mm/in	460 / 18	
OUTDOOR FAN MOTOR	TYPE		INDUCTION	
	QUANTITY		1	
	INDEX OF PROTECTION (IP)		IP24	
COMPRESSOR	TYPE		DC INVERTER TWIN ROTARY	
	OIL TYPE		POLYVINYLETHER OIL (PVE)	
	OIL AMOUNT	cm ³ / fl.oz	800 / 27.05	
INDOOR COIL	TUBE	MATERIAL		INNER GROOVED SEAMLESS COPPER TUBE
		DIAMETER	mm/in	7.0 / 0.276
		THICKNESS	mm/in	0.28 / 0.011
	FIN	MATERIAL		ALUMINIUM (HYDROPHILIC SLIT FIN TYPE)
		THICKNESS	mm/in	0.11 / 0.0043
		FACE AREA	m ² /ft ²	0.269 / 2.90
		ROW		2
		FIN PER INCH		18
	OUTDOOR COIL	TUBE	MATERIAL	
DIAMETER			mm/in	7.0 / 0.276
THICKNESS			mm/in	0.32 / 0.013
FIN		MATERIAL		ALUMINIUM (HYDROPHILIC SLIT FIN TYPE)
		THICKNESS	mm/in	0.11 / 0.0043
		FACE AREA	m ² /ft ²	0.62 / 6.67
		ROW		2
		FIN PER INCH		20
FILTRATION		TYPE		SARANET
	QUANTITY	pc	2	
	DIMENSION (L x W x t)	mm/in	386 x 364.3 x 1.5 / 15.2 x 14.3 x 0.06	
	TYPE		ANTI-MICROBIAL	
	QUANTITY	pc	1	
	DIMENSION (L x W x t)	mm/in	248 x 43 x 5 / 9.8 x 1.7 x 0.2	
	TYPE		TITANIUM OXIDE	
	QUANTITY	pc	1	
DIMENSION (L x W x t)	mm/in	248 x 43 x 5 / 9.8 x 1.7 x 0.2		
CASING	INDOOR UNIT	MATERIAL	HIGH IMPACT POLYSTYRENE	
		COLOUR	LIGHT GREY	
	OUTDOOR UNIT	MATERIAL	GALVANISED MILD STEEL	
		COLOUR	LIGHT GREY	

1) ALL SPECIFICATION ARE SUBJECTED TO CHANGE BY THE MANUFACTURER WITHOUT PRIOR NOTICE

Components Data

MODEL	OUTDOOR UNIT		M5MSX030A			
	INDOOR UNIT		M5WMX010G	M5WMX015G	M5WMX020G	
INDOOR FAN	TYPE		ANTI FUNGUS CROSS FLOW FAN			
	QUANTITY		1	1	1	
	MATERIAL		ACRYLO NITRILE STYRENE			
	DRIVE		DIRECT			
	DIAMETER	mm/in	87 / 3.4			
	LENGTH	mm/in	636 / 25.0			
INDOOR FAN MOTOR	TYPE		INDUCTION			
	Q'TY		1			
	INDEX OF PROTECTION (IP)		IP24			
OUTDOOR FAN	TYPE		PROPELLER			
	QUANTITY		1			
	MATERIAL		GLASS REINFORCED ACRLY STYRENE RESIN			
	DIAMETER	mm/in	460 / 18			
OUTDOOR FAN MOTOR	TYPE		INDUCTION			
	QUANTITY		1			
	INDEX OF PROTECTION (IP)		IP24			
COMPRESSOR	TYPE		DC INVERTER TWIN ROTARY			
	OIL TYPE		POLYVINYLETHER OIL (PVE)			
	OIL AMOUNT	cm ³ / fl.oz	800 / 27.05			
INDOOR COIL	TUBE	MATERIAL		SEAMLESS INNER GROOVED COPPER TUBE		
		DIAMETER	mm/in	7 / 0.276		
		THICKNESS	mm/in	0.28 / 0.011		
	FIN	MATERIAL		ALUMINIUM (HYDROPHILIC)		
		THICKNESS	mm/in	0.11 / 0.0043		
		FACE AREA	m ² /ft ²	0.318 / 3.42		
		ROW	2			
		FIN PER INCH	18			
OUTDOOR COIL	TUBE	MATERIAL		INNER GROOVED SEAMLESS COPPER TUBE		
		DIAMETER	mm/in	7.0 / 0.276		
		THICKNESS	mm/in	0.32 / 0.013		
	FIN	MATERIAL		ALUMINIUM (HYDROPHILIC SLIT FIN TYPE)		
		THICKNESS	mm/in	0.11 / 0.0043		
		FACE AREA	m ² /ft ²	0.62 / 6.67 + 0.28 / 3.06		
		ROW	2 + 1			
		FIN PER INCH	18			
FILTRATION	TYPE		SARANET			
	QUANTITY	pc	2			
	DIMENSION (L x W x t)	mm/in	386 x 364.3 x 1.5 / 15.2 x 14.3 x 0.06			
	TYPE		ANTI-MICROBIAL			
	QUANTITY	pc	1			
	DIMENSION (L x W x t)	mm/in	248 x 43 x 5 / 9.8 x 1.7 x 0.2			
	TYPE		TITANIUM OXIDE			
	QUANTITY	pc	1			
DIMENSION (L x W x t)	mm/in	248 x 43 x 5 / 9.8 x 1.7 x 0.2				
CASING	INDOOR UNIT	MATERIAL	HIGH IMPACT POLYSTYRENE			
		COLOUR	LIGHT GREY			
	OUTDOOR UNIT	MATERIAL	GALVANISED MILD STEEL			
		COLOUR	LIGHT GREY			

1) ALL SPECIFICATION ARE SUBJECTED TO CHANGE BY THE MANUFACTURER WITHOUT PRIOR NOTICE

2) ALL SPECIFICATION ARE TENTATIVE SPECIFICATION AT THE TIME OF PRINTING. PLEASE CONSULT YOUR DEALER FOR CONFIRMATION.

Components Data

MODEL	OUTDOOR UNIT		M5MSX 020AR		
	INDOOR UNIT		M5WMX 010GR	M5WMX 015GR	
INDOOR FAN	TYPE		ANTI FUNGUS CROSS FLOW FAN		
	QUANTITY		1	1	
	MATERIAL		ACRYLO NITRILE STYRENE		
	DRIVE		DIRECT		
	DIAMETER	mm/in	87 / 3.4		
	LENGTH	mm/in	636 / 25.0		
INDOOR FAN MOTOR	TYPE		INDUCTION		
	Q'TY		1		
	INDEX OF PROTECTION (IP)		IP24		
OUTDOOR FAN	TYPE		PROPELLER FAN		
	QUANTITY		1		
	MATERIAL		GLASS REINFORCED ACRYL STYRENE RESIN		
	DRIVE		DIRECT		
	DIAMETER	mm/in	460 / 18.11		
OUTDOOR FAN MOTOR	TYPE		INDUCTION		
	QUANTITY		1		
	INDEX OF PROTECTION (IP)		IP24		
COMPRESSOR	TYPE		DC BRUSHLESS SCROLL		
	OIL TYPE		POLYOESTER OIL (POE)		
	OIL AMOUNT	cm ³ / fl.oz	480 / 16.23		
INDOOR COIL	TUBE	MATERIAL		INNER GROOVED SEAMLESS COPPER TUBE	
		DIAMETER	mm/in	7.0 / 0.276	
		THICKNESS	mm/in	0.28 / 0.011	
	FIN	MATERIAL		ALUMINIUM (HYDROPHILIC SLIT FIN TYPE)	
		THICKNESS	mm/in	0.11 / 0.0043	
		FACE AREA	m ² /ft ²	0.193 / 2.08	
		ROW		2	
		FIN PER INCH		18	
OUTDOOR COIL	TUBE	MATERIAL		INNER GROOVED SEAMLESS COPPER TUBE	
		DIAMETER	mm/in	7.0 / 0.276	
		THICKNESS	mm/in	0.32 / 0.013	
	FIN	MATERIAL		ALUMINIUM (HYDROPHILIC SLIT FIN TYPE)	
		THICKNESS	mm/in	0.11 / 0.0043	
		FACE AREA	m ² /ft ²	0.62 / 6.67	
		ROW		2	
		FIN PER INCH		20	
FILTRATION	TYPE		SARANET		
	QUANTITY	pc	2		
	DIMENSION (L x W x t)	mm/in	386 x 364.3 x 1.5 / 15.2 x 14.3 x 0.06		
	TYPE		ANTI-MICROBIAL		
	QUANTITY	pc	1		
	DIMENSION (L x W x t)	mm/in	248 x 43 x 5 / 9.8 x 1.7 x 0.2		
	TYPE		TITANIUM OXIDE		
	QUANTITY	pc	1		
DIMENSION (L x W x t)	mm/in	248 x 43 x 5 / 9.8 x 1.7 x 0.2			
CASING	INDOOR UNIT	MATERIAL	HIGH IMPACT POLYSTYRENE		
		COLOUR	LIGHT GREY		
	OUTDOOR UNIT	MATERIAL	GALVANISED MILD STEEL		
		COLOUR	LIGHT GREY		

1) ALL SPECIFICATION ARE SUBJECTED TO CHANGE BY THE MANUFACTURER WITHOUT PRIOR NOTICE

2) ALL SPECIFICATION ARE TENTATIVE SPECIFICATION AT THE TIME OF PRINTING. PLEASE CONSULT YOUR DEALER FOR CONFIRMATION.

Components Data

MODEL	OUTDOOR UNIT		M5MSX 025AR	
	INDOOR UNIT		M5WMX 010GR	M5WMX 015GR
INDOOR FAN	TYPE		ANTI FUNGUS CROSS FLOW FAN	
	QUANTITY		1	1
	MATERIAL		ACRYLO NITRILE STYRENE	
	DRIVE		DIRECT	
	DIAMETER	mm/in	87 / 3.4	
	LENGTH	mm/in	636 / 25.0	
INDOOR FAN MOTOR	TYPE		INDUCTION	
	Q'TY		1	
	INDEX OF PROTECTION (IP)		IP24	
OUTDOOR FAN	TYPE		PROPELLER	
	QUANTITY		1	
	MATERIAL		GLASS REINFORCED ACRYL STYRENE RESIN	
	DIAMETER	mm/in	460 / 18	
OUTDOOR FAN MOTOR	TYPE		INDUCTION	
	QUANTITY		1	
	INDEX OF PROTECTION (IP)		IP24	
COMPRESSOR	TYPE		DC INVERTER TWIN ROTARY	
	OIL TYPE		POLYVINYLETHER OIL (PVE)	
	OIL AMOUNT	cm ³ / fl.oz	800 / 27.05	
INDOOR COIL	TUBE	MATERIAL	INNER GROOVED SEAMLESS COPPER TUBE	
		DIAMETER	mm/in	7.0 / 0.276
		THICKNESS	mm/in	0.28 / 0.011
	FIN	MATERIAL	ALUMINIUM (HYDROPHILIC SLIT FIN TYPE)	
		THICKNESS	mm/in	0.11 / 0.0043
		FACE AREA	m ² /ft ²	0.193 / 2.08
		ROW		2
		FIN PER INCH		18
OUTDOOR COIL	TUBE	MATERIAL	INNER GROOVED SEAMLESS COPPER TUBE	
		DIAMETER	mm/in	7.0 / 0.276
		THICKNESS	mm/in	0.32 / 0.013
	FIN	MATERIAL	ALUMINIUM (HYDROPHILIC SLIT FIN TYPE)	
		THICKNESS	mm/in	0.11 / 0.0043
		FACE AREA	m ² /ft ²	0.62 / 6.67
		ROW		2
		FIN PER INCH		20
FILTRATION	TYPE		SARANET	
	QUANTITY	pc	2	
	DIMENSION (L x W x t)	mm/in	386 x 364.3 x 1.5 / 15.2 x 14.3 x 0.06	
	TYPE		ANTI-MICROBIAL	
	QUANTITY	pc	1	
	DIMENSION (L x W x t)	mm/in	248 x 43 x 5 / 9.8 x 1.7 x 0.2	
	TYPE		TITANIUM OXIDE	
	QUANTITY	pc	1	
	DIMENSION (L x W x t)	mm/in	248 x 43 x 5 / 9.8 x 1.7 x 0.2	
CASING	INDOOR UNIT	MATERIAL	HIGH IMPACT POLYSTYRENE	
		COLOUR	LIGHT GREY	
	OUTDOOR UNIT	MATERIAL	GALVANISED MILD STEEL	
		COLOUR	LIGHT GREY	

1) ALL SPECIFICATION ARE SUBJECTED TO CHANGE BY THE MANUFACTURER WITHOUT PRIOR NOTICE

Components Data

MODEL	OUTDOOR UNIT		M5MSX 025AR	
	INDOOR UNIT		M5WMX 020GR	
INDOOR FAN	TYPE		ANTI FUNGUS CROSS FLOW FAN	
	QUANTITY		1	
	MATERIAL		ACRYLO NITRILE STYRENE	
	DRIVE		DIRECT	
	DIAMETER	mm/in	87 / 3.4	
	LENGTH	mm/in	636 / 25.0	
INDOOR FAN MOTOR	TYPE		INDUCTION	
	Q'TY		1	
	INDEX OF PROTECTION (IP)		IP24	
OUTDOOR FAN	TYPE		PROPELLER	
	QUANTITY		1	
	MATERIAL		GLASS REINFORCED ACRYL STYRENE RESIN	
	DRIVE		DIRECT	
	DIAMETER	mm/in	460 / 18	
OUTDOOR FAN MOTOR	TYPE		INDUCTION	
	QUANTITY		1	
	INDEX OF PROTECTION (IP)		IP24	
COMPRESSOR	TYPE		DC INVERTER TWIN ROTARY	
	OIL TYPE		POLYVINYLETHER OIL (PVE)	
	OIL AMOUNT	cm ³ / fl.oz	800 / 27.05	
INDOOR COIL	TUBE	MATERIAL	INNER GROOVED SEAMLESS COPPER TUBE	
		DIAMETER	mm/in	7.0 / 0.276
		THICKNESS	mm/in	0.28 / 0.011
	FIN	MATERIAL	ALUMINIUM (HYDROPHILIC SLIT FIN TYPE)	
		THICKNESS	mm/in	0.11 / 0.0043
		FACE AREA	m ² /ft ²	0.269 / 2.90
		ROW	2	
		FIN PER INCH	18	
OUTDOOR COIL	TUBE	MATERIAL	INNER GROOVED SEAMLESS COPPER TUBE	
		DIAMETER	mm/in	7.0 / 0.276
		THICKNESS	mm/in	0.32 / 0.013
	FIN	MATERIAL	ALUMINIUM (HYDROPHILIC SLIT FIN TYPE)	
		THICKNESS	mm/in	0.11 / 0.0043
		FACE AREA	m ² /ft ²	0.62 / 6.67
		ROW	2	
		FIN PER INCH	20	
FILTRATION	TYPE		SARANET	
	QUANTITY	pc	2	
	DIMENSION (L x W x t)	mm/in	386 x 364.3 x 1.5 / 15.2 x 14.3 x 0.06	
	TYPE		ANTI-MICROBIAL	
	QUANTITY	pc	1	
	DIMENSION (L x W x t)	mm/in	248 x 43 x 5 / 9.8 x 1.7 x 0.2	
	TYPE		TITANIUM OXIDE	
	QUANTITY	pc	1	
	DIMENSION (L x W x t)	mm/in	248 x 43 x 5 / 9.8 x 1.7 x 0.2	
CASING	INDOOR UNIT	MATERIAL	HIGH IMPACT POLYSTYRENE	
		COLOUR	LIGHT GREY	
	OUTDOOR UNIT	MATERIAL	GALVANISED MILD STEEL	
		COLOUR	LIGHT GREY	

1) ALL SPECIFICATION ARE SUBJECTED TO CHANGE BY THE MANUFACTURER WITHOUT PRIOR NOTICE

Components Data

MODEL	OUTDOOR UNIT		M5MSX 030AR			
	INDOOR UNIT		M5WMX 010GR	M5WMX 015GR	M5WMX 020GR	
INDOOR FAN	TYPE		ANTI FUNGUS CROSS FLOW FAN			
	QUANTITY		1	1	1	
	MATERIAL		ACRYLO NITRILE STYRENE			
	DRIVE		DIRECT			
	DIAMETER	mm/in	87 / 3.4			
	LENGTH	mm/in	636 / 25.0			
INDOOR FAN MOTOR	TYPE		INDUCTION			
	Q'TY		1			
	INDEX OF PROTECTION (IP)		IP24			
OUTDOOR FAN	TYPE		PROPELLER			
	QUANTITY		1			
	MATERIAL		GLASS REINFORCED ACRLY STYRENE RESIN			
	DIAMETER	mm/in	460 / 18			
OUTDOOR FAN MOTOR	TYPE		INDUCTION			
	QUANTITY		1			
	INDEX OF PROTECTION (IP)		IP24			
COMPRESSOR	TYPE		DC INVERTER TWIN ROTARY			
	OIL TYPE		POLYVINYLETHER OIL (PVE)			
	OIL AMOUNT	cm ³ / fl.oz	800 / 27.05			
INDOOR COIL	TUBE	MATERIAL		SEAMLESS INNER GROOVED COPPER TUBE		
		DIAMETER	mm/in	7 / 0.276		
		THICKNESS	mm/in	0.28 / 0.011		
	FIN	MATERIAL		ALUMINIUM (HYDROPHILIC)		
		THICKNESS	mm/in	0.11 / 0.0043		
		FACE AREA	m ² /ft ²	0.318 / 3.42		
		ROW	2			
		FIN PER INCH	18			
OUTDOOR COIL	TUBE	MATERIAL		INNER GROOVED SEAMLESS COPPER TUBE		
		DIAMETER	mm/in	7.0 / 0.276		
		THICKNESS	mm/in	0.32 / 0.013		
	FIN	MATERIAL		ALUMINIUM (HYDROPHILIC SLIT FIN TYPE)		
		THICKNESS	mm/in	0.11 / 0.0043		
		FACE AREA	m ² /ft ²	0.62 / 6.67 + 0.28 / 3.06		
		ROW	2 + 1			
		FIN PER INCH	18			
FILTRATION	TYPE		SARANET			
	QUANTITY	pc	2			
	DIMENSION (L x W x t)	mm/in	386 x 364.3 x 1.5 / 15.2 x 14.3 x 0.06			
	TYPE		ANTI-MICROBIAL			
	QUANTITY	pc	1			
	DIMENSION (L x W x t)	mm/in	248 x 43 x 5 / 9.8 x 1.7 x 0.2			
	TYPE		TITANIUM OXIDE			
	QUANTITY	pc	1			
DIMENSION (L x W x t)	mm/in	248 x 43 x 5 / 9.8 x 1.7 x 0.2				
CASING	INDOOR UNIT	MATERIAL	HIGH IMPACT POLYSTYRENE			
		COLOUR	LIGHT GREY			
	OUTDOOR UNIT	MATERIAL	GALVANISED MILD STEEL			
		COLOUR	LIGHT GREY			

1) ALL SPECIFICATION ARE SUBJECTED TO CHANGE BY THE MANUFACTURER WITHOUT PRIOR NOTICE

2) ALL SPECIFICATION ARE TENTATIVE SPECIFICATION AT THE TIME OF PRINTING. PLEASE CONSULT YOUR DEALER FOR CONFIRMATION.

Performance Data

Capacity Rating

Specifications for M5MSX020A/AR with M5WMX-G/GR

CONDITION	INDOOR OPERATING UNIT	NOMINAL COOLING CAPACITY							INPUT POWER (W)	RUNNING CURRENT (A)			
		INDIVIDUAL INDOOR		TOTAL									
		A (BTU/h)	B (BTU/h)	BTU/h		kcal/h		KW					
		RATED	RATED	RATED	(MAX)	RATED	(MAX)	RATED			(MAX)		
Cooling	10	9000	-	9000	(10000)	2268	(2520)	2.64	(2.93)	870	(960)	3.92	(4.32)
	15	12000	-	12000	(13000)	3024	(3276)	3.52	(3.81)	1145	(1440)	5.15	(6.48)
	10 + 10	9000	9000	18000	(21000)	4536	(5292)	5.28	(6.15)	1420	(1870)	6.39	(8.42)
	10 + 15	9000	9500	18500	(21000)	4662	(5292)	5.42	(6.15)	1460	(1870)	6.57	(8.42)
	15 + 15	9500	9500	19000	(21000)	4788	(5292)	5.57	(6.15)	1500	(1870)	6.75	(8.42)
Heating	10	11000	-	11000	(12000)	2772	(3024)	3.22	(3.52)	1040	(1135)	4.68	(5.11)
	15	13000	-	13000	(15000)	3276	(3780)	3.81	(4.40)	1230	(1660)	5.54	(7.47)
	10 + 10	10000	10000	20000	(23000)	5040	(5796)	5.86	(6.74)	1550	(1950)	6.98	(8.78)
	10 + 15	10000	10500	20500	(23000)	5166	(5796)	6.01	(6.74)	1590	(1950)	7.16	(8.78)
	15 + 15	10500	10500	21000	(23000)	5292	(5796)	6.15	(6.74)	1630	(1950)	7.34	(8.78)

Specifications for M5MSX025A/AR with M5WMX-G/GR

CONDITION	INDOOR OPERATING	NOMINAL COOLING CAPACITY									INPUT POWER (W)		RUNNING CURRENT (A)	
		INDIVIDUAL INDOOR			TOTAL									
	UNIT (M5WMX-G/GR)	A	B	C	BTU/h		kcal/h		KW		RATED	(MAX)	RATED	(MAX)
Cooling	10	9000	-	-	9000	(10000)	2268	(2520)	2.64	(2.93)	592	(724)	3.18	(3.39)
	15	12000	-	-	12000	(13500)	3024	(3402)	3.52	(3.96)	969	(1207)	4.44	(5.47)
	20	18000	-	-	18000	(19000)	4536	(4788)	5.28	(5.57)	1595	(1944)	7.22	(8.71)
	10 + 10	9000	9000	-	18000	(20000)	4536	(5040)	5.28	(5.86)	1474	(1838)	6.68	(8.32)
	10 + 15	8000	12000	-	20000	(21000)	5040	(5292)	5.86	(6.15)	1573	(2065)	9.26	(9.35)
	10 + 20	7400	14600	-	22000	(24000)	5544	(6048)	6.45	(7.03)	1802	(2205)	8.08	(9.86)
	15 + 15	11000	11000	-	22000	(24000)	5544	(6048)	6.45	(7.03)	1814	(2200)	8.13	(9.86)
	15 + 20	8800	13200	-	22000	(24000)	5544	(6048)	6.45	(7.03)	1814	(2200)	8.13	(9.86)
	10 + 10 + 10	7300	7300	7300	21900	(24000)	5519	(6048)	6.42	(7.03)	1814	(2200)	8.13	(9.86)
	10 + 10 + 15	6600	6600	8800	22000	(24000)	5544	(6048)	6.45	(7.03)	1814	(2200)	8.13	(9.86)
	10 + 10 + 20	5500	5500	11000	22000	(24000)	5544	(6048)	6.45	(7.03)	1814	(2200)	8.13	(9.86)
	10 + 15 + 15	6020	7990	7990	22000	(24000)	5544	(6048)	6.45	(7.03)	1814	(2200)	8.13	(9.86)
	10 + 15 + 20	5080	6750	10170	22000	(24000)	5544	(6048)	6.45	(7.03)	1814	(2200)	8.13	(9.86)
	15 + 15 + 15	7350	7350	7350	22050	(24000)	5557	(6048)	6.46	(7.03)	1814	(2200)	8.13	(9.86)
Heating	10	11000	-	-	11000	(12000)	2772	(3024)	3.22	(3.52)	1317	(1618)	5.97	(7.25)
	15	11000	-	-	11000	(13000)	2772	(3276)	3.22	(3.81)	1676	(2149)	7.51	(9.53)
	20	19000	-	-	19000	(20000)	4788	(5040)	5.57	(5.86)	2133	(2489)	9.46	(11.04)
	10 + 10	11000	11000	-	22000	(23000)	5544	(5796)	6.45	(6.74)	1953	(2248)	8.85	(10.18)
	10 + 15	10000	13000	-	23000	(24000)	5796	(6048)	6.74	(7.03)	2042	(2346)	9.16	(10.40)
	10 + 20	8000	16000	-	24000	(26000)	6048	(6552)	7.03	(7.62)	2033	(2527)	9.21	(11.30)
	15 + 15	12000	12000	-	24000	(26000)	6048	(6552)	7.03	(7.62)	1990	(2410)	8.92	(10.70)
	15 + 20	9600	14400	-	24000	(26000)	6048	(6552)	7.03	(7.62)	1990	(2410)	8.92	(10.70)
	10 + 10 + 10	8300	8300	8300	24900	(26000)	6275	(6552)	7.30	(7.62)	1900	(2155)	8.52	(9.57)
	10 + 10 + 15	7300	7300	10400	25000	(26000)	6300	(6552)	7.33	(7.62)	1900	(2155)	8.52	(9.57)
	10 + 10 + 20	6000	6000	13000	25000	(26000)	6300	(6552)	7.33	(7.62)	1900	(2155)	8.52	(9.57)
	10 + 15 + 15	7000	9000	9000	25000	(26000)	6300	(6552)	7.33	(7.62)	1900	(2155)	8.52	(9.57)
	10 + 15 + 20	6700	7800	10500	25000	(26000)	6300	(6552)	7.33	(7.62)	1900	(2155)	8.52	(9.57)
	15 + 15 + 15	8350	8350	8350	25050	(26000)	6312	(6552)	7.34	(7.62)	1900	(2155)	8.52	(9.57)

Specifications for M5MSX030A/AR with M5WMX-G/GR

CONDITION	INDOOR OPERATING UNIT (M5WMX-G/GR)	NOMINAL COOLING CAPACITY									INPUT POWER		RUNNING CURRENT		
		INDIVIDUAL INDOOR				TOTAL					POWER (W)		CURRENT (A)		
		A	B	C	C	BTU/h		kcal/h		KW		RATED	(MAX)	RATED	(MAX)
		RATED	RATED	RATED	RATED	RATED	(MAX)	RATED	(MAX)	RATED	(MAX)				
Cooling	10	9500	-	-	-	9500	(10800)	2394	(2722)	2.78	(3.17)	860	(1007)	3.82	(4.47)
	15	12000	-	-	-	12000	(14400)	3024	(3629)	3.52	(4.22)	1159	(1743)	5.14	(7.73)
	20	18000	-	-	-	18000	(18500)	4536	(4662)	5.28	(5.42)	2003	(2554)	8.89	(11.33)
	10 + 10	9000	9000	-	-	18000	(20000)	4536	(5040)	5.28	(5.86)	1657	(1941)	7.35	(8.61)
	10 + 15	9000	12000	-	-	21000	(23000)	5292	(5796)	6.15	(6.74)	2057	(2233)	9.13	(9.90)
	10 + 20	8300	12500	-	-	20800	(24000)	5242	(6048)	6.10	(7.03)	2167	(2330)	9.61	(10.34)
	15 + 15	10500	10500	-	-	21000	(24000)	5292	(6048)	6.15	(7.03)	2167	(2330)	9.61	(10.34)
	15 + 20	9300	11700	-	-	21000	(24000)	5292	(6048)	6.15	(7.03)	2167	(2330)	9.61	(10.34)
	10 + 10 + 10	7830	7830	7830	-	23490	(29000)	5919	(7308)	6.88	(8.50)	2128	(2815)	9.44	(12.49)
	10 + 10 + 15	7500	7500	8500	-	23500	(29000)	5922	(7308)	6.89	(8.50)	2128	(2815)	9.44	(12.49)
	10 + 10 + 20	7150	7150	10200	-	24500	(29000)	6174	(7308)	7.18	(8.50)	2218	(2815)	9.84	(12.49)
	10 + 15 + 15	7500	8500	8500	-	24500	(29000)	6174	(7308)	7.18	(8.50)	2218	(2815)	9.84	(12.49)
	10 + 15 + 20	6600	8500	9400	-	24500	(29000)	6174	(7308)	7.18	(8.50)	2218	(2815)	9.84	(12.49)
	15 + 15 + 15	8166	8166	8166	-	24498	(29000)	6173	(7308)	7.18	(8.50)	2218	(2815)	9.84	(12.49)
	10 + 10 + 10 + 10	6500	6500	6500	6500	26000	(29000)	6552	(7308)	7.62	(8.50)	2354	(2815)	10.44	(12.49)
	10 + 10 + 10 + 15	6000	6000	6000	8000	26000	(29000)	6552	(7308)	7.62	(8.50)	2354	(2815)	10.44	(12.49)
	10 + 10 + 10 + 20	5100	5100	5100	10700	26000	(29000)	6552	(7308)	7.62	(8.50)	2354	(2815)	10.44	(12.49)
	10 + 10 + 15 + 15	5300	5300	7700	7700	26000	(29000)	6552	(7308)	7.62	(8.50)	2354	(2815)	10.44	(12.49)
	10 + 10 + 15 + 20	5000	5000	6700	9300	26000	(29000)	6552	(7308)	7.62	(8.50)	2354	(2815)	10.44	(12.49)
10 + 15 + 15 + 15	5000	7000	7000	7000	26000	(29000)	6552	(7308)	7.62	(8.50)	2354	(2815)	10.44	(12.49)	
15 + 15 + 15 + 15	6500	6500	6500	6500	26000	(29000)	6552	(7308)	7.62	(8.50)	2354	(2815)	10.44	(12.49)	
Heating	10	11000	-	-	-	11000	(13200)	2772	(3326)	3.22	(3.87)	1355	(1975)	6.01	(8.76)
	15	14000	-	-	-	14000	(16800)	3528	(4234)	4.10	(4.92)	1955	(2949)	8.67	(13.08)
	20	20000	-	-	-	20000	(22800)	5040	(5746)	5.86	(6.68)	2734	(3697)	12.13	(16.40)
	10 + 10	11000	11000	-	-	22000	(23000)	5544	(5796)	6.45	(6.74)	1983	(2238)	8.80	(9.93)
	10 + 15	11000	13000	-	-	24000	(26000)	6048	(6552)	7.03	(7.62)	1983	(2238)	8.80	(9.93)
	10 + 20	9500	15000	-	-	24500	(32000)	6174	(8064)	7.18	(9.38)	2030	(2755)	9.01	(12.22)
	15 + 15	12250	12250	-	-	24500	(28000)	6174	(7056)	7.18	(8.21)	2030	(2755)	9.01	(12.22)
	15 + 20	10500	14000	-	-	24500	(32000)	6174	(8064)	7.18	(9.38)	2030	(2755)	9.01	(12.22)
	10 + 10 + 10	8500	8500	8500	-	25500	(32000)	6426	(8064)	7.47	(9.38)	2030	(2755)	9.01	(12.22)
	10 + 10 + 15	8000	8000	9500	-	25500	(32000)	6426	(8064)	7.47	(9.38)	2030	(2755)	9.01	(12.22)
	10 + 10 + 20	6500	6500	12500	-	25500	(32000)	6426	(8064)	7.47	(9.38)	2030	(2755)	9.01	(12.22)
	10 + 15 + 15	7000	9250	9250	-	25500	(32000)	6426	(8064)	7.47	(9.38)	2030	(2755)	9.01	(12.22)
	10 + 15 + 20	6000	8000	11500	-	25500	(32000)	6426	(8064)	7.47	(9.38)	2030	(2755)	9.01	(12.22)
	15 + 15 + 15	8500	8500	8500	-	25500	(32000)	6426	(8064)	7.47	(9.38)	2030	(2755)	9.01	(12.22)
	10 + 10 + 10 + 10	7000	7000	7000	7000	28000	(32000)	7056	(8064)	8.21	(9.38)	2030	(2755)	9.01	(12.22)
	10 + 10 + 10 + 15	6500	6500	6500	8500	28000	(32000)	7056	(8064)	8.21	(9.38)	2030	(2755)	9.01	(12.22)
	10 + 10 + 10 + 20	5600	5600	5600	11200	28000	(32000)	7056	(8064)	8.21	(9.38)	2030	(2755)	9.01	(12.22)
	10 + 10 + 15 + 15	5500	5500	8500	8500	28000	(32000)	7056	(8064)	8.21	(9.38)	2030	(2755)	9.01	(12.22)
	10 + 10 + 15 + 20	5400	5400	6200	11000	28000	(32000)	7056	(8064)	8.21	(9.38)	2030	(2755)	9.01	(12.22)
10 + 15 + 15 + 15	6025	7325	7325	7325	28000	(32000)	7056	(8064)	8.21	(9.38)	2030	(2755)	9.01	(12.22)	
15 + 15 + 15 + 15	7000	7000	7000	7000	28000	(32000)	7056	(8064)	8.21	(9.38)	2030	(2755)	9.01	(12.22)	

Dimensional Data

Indoor Unit

Model : M5WMX 010 / 015G/GR

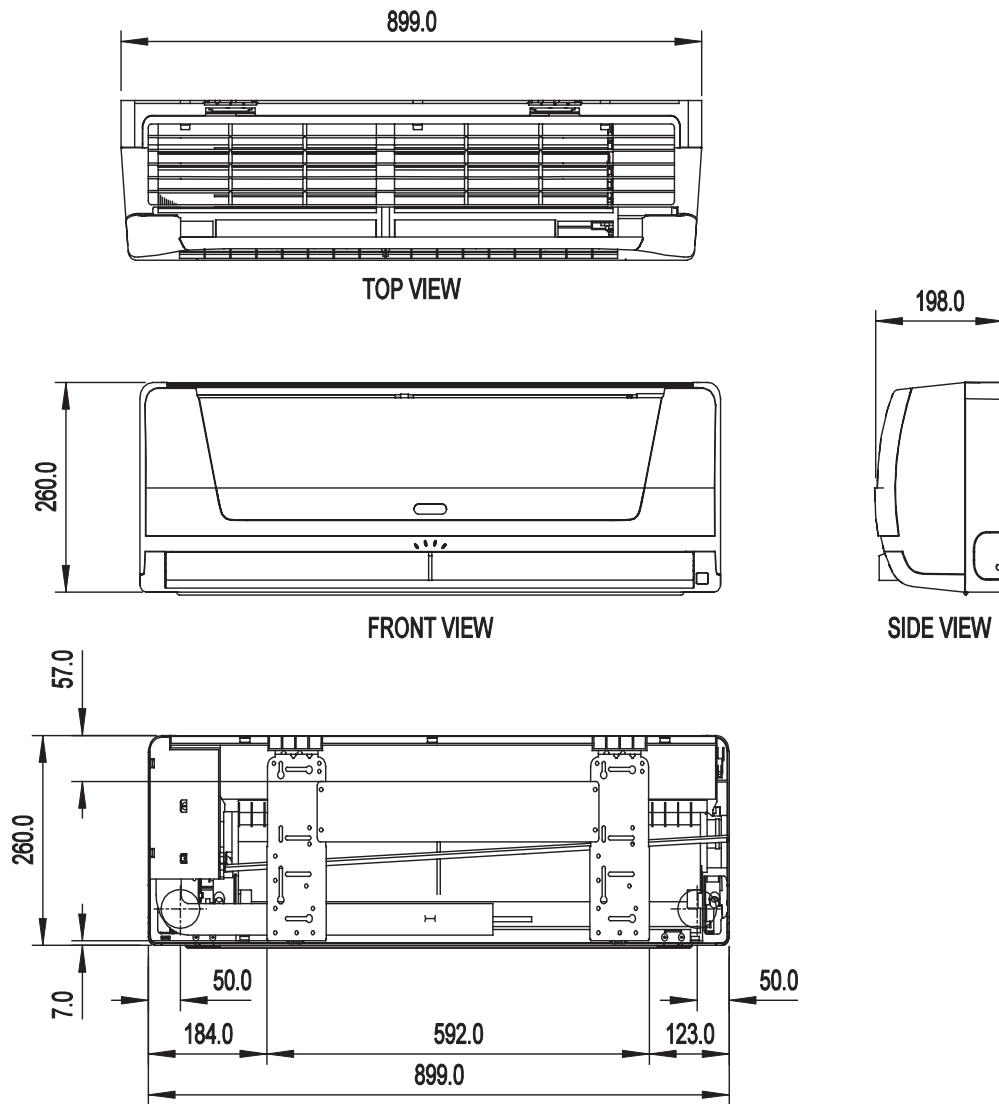

Note: Dimension in mm

Model : M5WMX 020G/GR

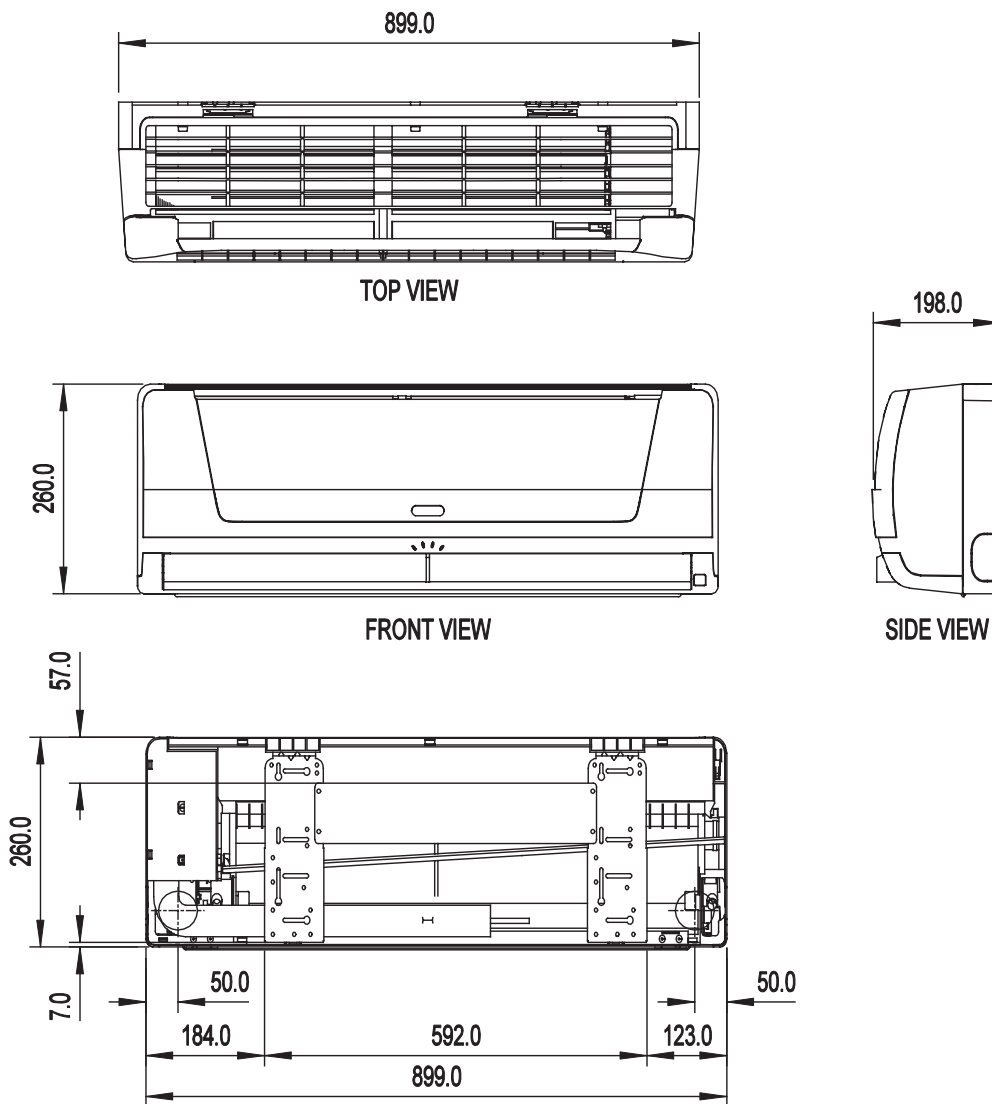

Note: Dimension in mm

Outdoor Unit
Model : M5MSX 020A/AR

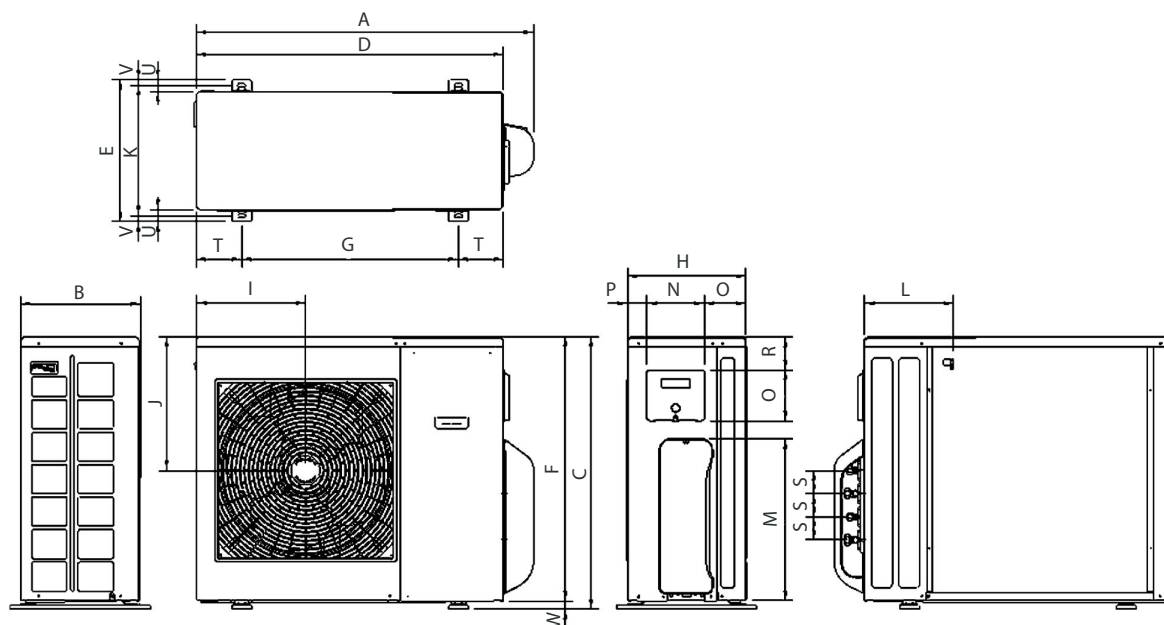

Dimension	A	B	C	D	E	F	G	H	I	J	K	L	M	N	O	P	Q	R	S	T	U	V	W
M5MSX 020A/AR	939	333	756	855	392	733	603	328	303	370	362	248	449	160	115	53	141	90	64	126	32	15	23
	(37)	(13,1)	(29,8)	(33,7)	(15,4)	(28,9)	(23,7)	(12,9)	(11,9)	(14,6)	(14,3)	(9,8)	(17,7)	(6,3)	(4,5)	(2,1)	(5,6)	(3,5)	(2,5)	(5)	(1,3)	(0,6)	(0,9)

Outdoor Unit
Model : M5MSX 025A/AR

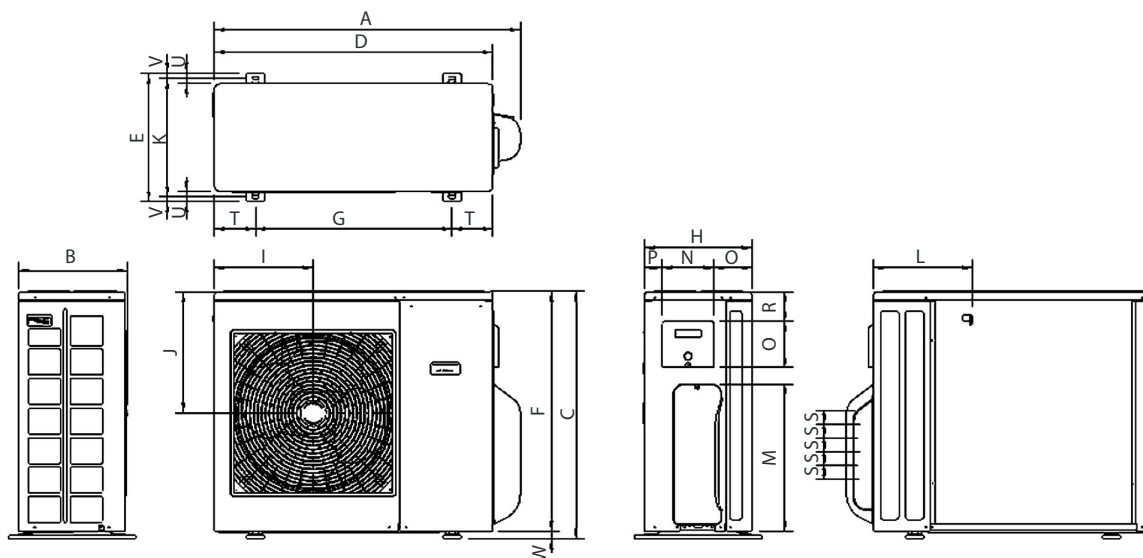

Dimension	A	B	C	D	E	F	G	H	I	J	K	L	M	N	O	P	Q	R	S	T	U	V	W
M5MSX 025A/AR	939	333	756	855	392	733	603	328	303	370	362	302	449	160	116	52	141	42	64	126	32	15	23
	(37)	(13,1)	(29,8)	(33,7)	(15,4)	(28,9)	(23,7)	(12,9)	(11,9)	(14,6)	(14,3)	(11,9)	(17,7)	(6,3)	(4,6)	(2)	(5,6)	(1,7)	(2,5)	(5)	(1,3)	(0,6)	(0,9)

Outdoor Unit
Model : M5MSX 030A/AR

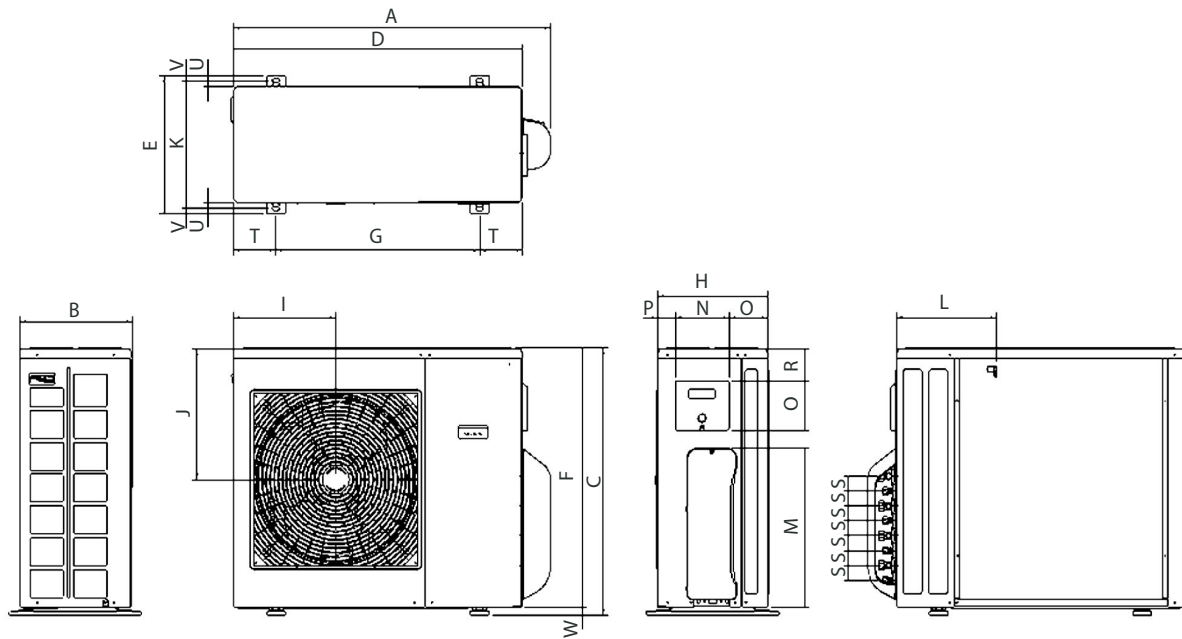

Dimension	A	B	C	D	E	F	G	H	I	J	K	L	M	N	O	P	Q	R	S	T	U	V	W
M5MSX	939	333	756	855	392	733	603	328	303	370	362	298	449	160	115	53	141	42	64	126	32	15	23
030A/AR	(37)	(13,1)	(29,8)	(33,7)	(15,4)	(28,9)	(23,7)	(12,9)	(11,9)	(14,6)	(14,3)	(11,7)	(17,7)	(6,3)	(4,5)	(2,1)	(5,6)	(1,7)	(2,5)	(5)	(1,3)	(0,6)	(0,9)

Electrical Data

Electrical Data - Cooling Only

MODEL	OUTDOOR UNIT		M5MSX 020A	
	INDOOR UNIT		M5WMX 010G	M5WMX 015G
INDOOR MOTOR	INSULATION GRADE		E	
	POWER SOURCE	V/Ph/Hz	230 / 1 / 50	
	RATED INPUT POWER	W	38	40
	RATED RUNNING CURRENT	A	0.19	0.20
	MOTOR OUTPUT	W	17	
	POLES		4P	
OUTDOOR MOTOR	INSULATION GRADE		B	
	POWER SOURCE	V/Ph/Hz	230 / 1 / 50	
	RATED INPUT POWER	W	130	
	RATED RUNNING CURRENT	A	0.58	
	MOTOR OUTPUT	W	75	
	POLES		4P	
COMPRESSOR	INSULATION GRADE		E	
	POWER SOURCE	V/Ph/Hz	0-300/3/0-100	
	CAPACITOR	F	-	
	RATED INPUT POWER	W	1350	
	RATED RUNNING CURRENT	A	6.05	
	LOCKED ROTOR AMP.	A	30	

1) ALL SPECIFICATION ARE SUBJECTED TO CHANGE BY THE MANUFACTURER WITHOUT PRIOR NOTICE

2) ALL UNITS ARE BEING TESTED AND COMPLY TO ISO 5151.

3) ALL SPECIFICATION ARE TENTATIVE SPECIFICATION AT THE TIME OF PRINTING. PLEASE CONSULT YOUR DEALER FOR CONFIRMATION.

Electrical Data - Heatpump

MODEL	OUTDOOR UNIT		M5MSX 020AR	
	INDOOR UNIT		M5WMX 010GR	M5WMX 015GR
INDOOR MOTOR	INSULATION GRADE		E	
	POWER SOURCE	V/Ph/Hz	230 / 1 / 50	
	RATED INPUT POWER	W	38	40
	RATED RUNNING CURRENT	A	0.19	0.20
	MOTOR OUTPUT	W	17	
	POLES		4P	
OUTDOOR MOTOR	INSULATION GRADE		B	
	POWER SOURCE	V/Ph/Hz	230 / 1 / 50	
	RATED INPUT POWER	W	130	
	RATED RUNNING CURRENT	A	0.58	
	MOTOR OUTPUT	W	75	
	POLES		4P	
COMPRESSOR	INSULATION GRADE		E	
	POWER SOURCE	V/Ph/Hz	0-300/ 3/ 0-100	
	CAPACITOR	F	-	
	RATED INPUT POWER (COOLING)	W	1350	
	RATED INPUT POWER (HEATING)	W	1440	
	RATED RUNNING CURRENT (COOLING)	A	6.05	
	RATED RUNNING CURRENT (HEATING)	A	6.45	
	LOCKED ROTOR AMP.	A	30	

1) ALL SPECIFICATION ARE SUBJECTED TO CHANGE BY THE MANUFACTURER WITHOUT PRIOR NOTICE

2) ALL UNITS ARE BEING TESTED AND COMPLY TO ISO 5151.

3) ALL SPECIFICATION ARE TENTATIVE SPECIFICATION AT THE TIME OF PRINTING. PLEASE CONSULT YOUR DEALER FOR CONFIRMATION.

Electrical Data - Cooling Only

MODEL	OUTDOOR UNIT		M5MSX 025A	
	INDOOR UNIT		M5WMX 020G	
INDOOR MOTOR	INSULATION GRADE		E	
	POWER SOURCE	V/Ph/Hz	230 / 1 / 50	
	RATED INPUT POWER	W	60	
	RATED RUNNING CURRENT	A	0.31	
	MOTOR OUTPUT	W	40	
	POLES		4P	
OUTDOOR MOTOR	INSULATION GRADE		B	
	POWER SOURCE	V/Ph/Hz	230 / 1 / 50	
	RATED INPUT POWER	W	140	
	RATED RUNNING CURRENT	A	0.58	
	MOTOR OUTPUT	W	80	
	POLES		4P	
COMPRESSOR	INSULATION GRADE		E	
	POWER SOURCE	V/Ph/Hz	0-300/3/0-100	
	CAPACITOR	F	-	
	RATED INPUT POWER	W	1690	
	RATED RUNNING CURRENT	A	7.5	
	LOCKED ROTOR AMP.	A	30	

1) ALL SPECIFICATION ARE SUBJECTED TO CHANGE BY THE MANUFACTURER WITHOUT PRIOR NOTICE

2) ALL UNITS ARE BEING TESTED AND COMPLY TO ISO 5151.

3) ALL SPECIFICATION ARE TENTATIVE SPECIFICATION AT THE TIME OF PRINTING. PLEASE CONSULT YOUR DEALER FOR CONFIRMATION.

Electrical Data - Cooling Only

MODEL	OUTDOOR UNIT		M5MSX 025A	
	INDOOR UNIT		M5WMX 010G	M5WMX 015G
INDOOR MOTOR	INSULATION GRADE		E	
	POWER SOURCE	V/Ph/Hz	230 / 1 / 50	
	RATED INPUT POWER	W	38	40
	RATED RUNNING CURRENT	A	0.19	0.20
	MOTOR OUTPUT	W	17	
	POLES		4P	
OUTDOOR MOTOR	INSULATION GRADE		B	
	POWER SOURCE	V/Ph/Hz	230 / 1 / 50	
	RATED INPUT POWER	W	140	
	RATED RUNNING CURRENT	A	0.58	
	MOTOR OUTPUT	W	80	
	POLES		4P	
COMPRESSOR	INSULATION GRADE		E	
	POWER SOURCE	V/Ph/Hz	0-300/3/0-100	
	CAPACITOR	F	-	
	RATED INPUT POWER	W	1690	
	RATED RUNNING CURRENT	A	7.5	
	LOCKED ROTOR AMP.	A	30	

1) ALL SPECIFICATION ARE SUBJECTED TO CHANGE BY THE MANUFACTURER WITHOUT PRIOR NOTICE

2) ALL UNITS ARE BEING TESTED AND COMPLY TO ISO 5151.

3) ALL SPECIFICATION ARE TENTATIVE SPECIFICATION AT THE TIME OF PRINTING. PLEASE CONSULT YOUR DEALER FOR CONFIRMATION.

Electrical Data - HeatPump

MODEL	OUTDOOR UNIT		M5MSX 025AR	
	INDOOR UNIT		M5WMX 010GR	M5WMX 015GR
INDOOR MOTOR	INSULATION GRADE		E	
	POWER SOURCE	V/Ph/Hz	230 / 1 / 50	
	RATED INPUT POWER	W	38	40
	RATED RUNNING CURRENT	A	0.19	0.20
	MOTOR OUTPUT	W	17	
	POLES		4P	
OUTDOOR MOTOR	INSULATION GRADE		B	
	POWER SOURCE	V/Ph/Hz	230 / 1 / 50	
	RATED INPUT POWER	W	140	
	RATED RUNNING CURRENT	A	0.58	
	MOTOR OUTPUT	W	80	
COMPRESSOR	INSULATION GRADE		E	
	POWER SOURCE	V/Ph/Hz	0-300/3/0-100	
	CAPACITOR	F	-	
	RATED INPUT POWER (COOLING)	W	1690	
	RATED INPUT POWER (HEATING)	W	1700	
	RATED RUNNING CURRENT (COOLING)	A	7.5	
	RATED RUNNING CURRENT (HEATING)	A	7.61	
	LOCKED ROTOR AMP.	A	30	

1) ALL SPECIFICATION ARE SUBJECTED TO CHANGE BY THE MANUFACTURER WITHOUT PRIOR NOTICE

2) ALL UNITS ARE BEING TESTED AND COMPLY TO ISO 5151.

3) ALL SPECIFICATION ARE TENTATIVE SPECIFICATION AT THE TIME OF PRINTING. PLEASE CONSULT YOUR DEALER FOR CONFIRMATION.

Electrical Data - HeatPump

MODEL	OUTDOOR UNIT		M5MSX 025AR	
	INDOOR UNIT		M5WMX 020GR	
INDOOR MOTOR	INSULATION GRADE		E	
	POWER SOURCE	V/Ph/Hz	230 / 1 / 50	
	RATED INPUT POWER	W	60	
	RATED RUNNING CURRENT	A	0.31	
	MOTOR OUTPUT	W	40	
	POLES		4P	
OUTDOOR MOTOR	INSULATION GRADE		B	
	POWER SOURCE	V/Ph/Hz	230 / 1 / 50	
	RATED INPUT POWER	W	140	
	RATED RUNNING CURRENT	A	0.58	
	MOTOR OUTPUT	W	80	
COMPRESSOR	INSULATION GRADE		E	
	POWER SOURCE	V/Ph/Hz	0-300/3/0-100	
	CAPACITOR	F	-	
	RATED INPUT POWER (COOLING)	W	1690	
	RATED INPUT POWER (HEATING)	W	1700	
	RATED RUNNING CURRENT (COOLING)	A	7.5	
	RATED RUNNING CURRENT (HEATING)	A	7.61	
	LOCKED ROTOR AMP.	A	30	

1) ALL SPECIFICATION ARE SUBJECTED TO CHANGE BY THE MANUFACTURER WITHOUT PRIOR NOTICE

2) ALL UNITS ARE BEING TESTED AND COMPLY TO ISO 5151.

3) ALL SPECIFICATION ARE TENTATIVE SPECIFICATION AT THE TIME OF PRINTING. PLEASE CONSULT YOUR DEALER FOR CONFIRMATION.

Electrical Data - Cooling Only

MODEL	OUTDOOR UNIT		M5MSX030A		
	INDOOR UNIT		M5WMX 010G	M5WMX 015G	M5WMX 020G
INDOOR MOTOR	INSULATION GRADE		E		
	POWER SOURCE	V/Ph/Hz	230 / 1 / 50		
	RATED INPUT POWER	W	38	40	60
	RATED RUNNING CURRENT	A	0.19	0.20	0.31
	MOTOR OUTPUT	W	17	17	40
	POLES		4P		
OUTDOOR MOTOR	INSULATION GRADE		B		
	POWER SOURCE	V/Ph/Hz	230 / 1 / 50		
	RATED INPUT POWER	W	170		
	RATED RUNNING CURRENT	A	0.75		
	MOTOR OUTPUT	W	80		
COMPRESSOR	INSULATION GRADE		E		
	POWER SOURCE	V/Ph/Hz	0-300/3/0-100		
	CAPACITOR	F	-		
	RATED INPUT POWER	W	1690		
	RATED RUNNING CURRENT	A	7.5		
	LOCKED ROTOR AMP.	A	30		

1) ALL SPECIFICATION ARE SUBJECTED TO CHANGE BY THE MANUFACTURER WITHOUT PRIOR NOTICE

2) ALL UNITS ARE BEING TESTED AND COMPLY TO ISO 5151.

3) ALL SPECIFICATION ARE TENTATIVE SPECIFICATION AT THE TIME OF PRINTING. PLEASE CONSULT YOUR DEALER FOR CONFIRMATION.

Electrical Data - HeatPump

MODEL	OUTDOOR UNIT		M5MSX 030AR		
	INDOOR UNIT		M5WMX 010GR	M5WMX 015GR	M5WMX 020GR
INDOOR MOTOR	INSULATION GRADE		E		
	POWER SOURCE	V/Ph/Hz	230 / 1 / 50		
	RATED INPUT POWER	W	38	40	60
	RATED RUNNING CURRENT	A	0.19	0.20	0.31
	MOTOR OUTPUT	W	17	17	40
	POLES		4P		
OUTDOOR MOTOR	INSULATION GRADE		B		
	POWER SOURCE	V/Ph/Hz	230 / 1 / 50		
	RATED INPUT POWER	W	170		
	RATED RUNNING CURRENT	A	0.75		
	MOTOR OUTPUT	W	80		
COMPRESSOR	INSULATION GRADE		E		
	POWER SOURCE	V/Ph/Hz	0-300/3/0-100		
	CAPACITOR	F	-		
	RATED INPUT POWER (COOLING)	W	1690		
	RATED INPUT POWER (HEATING)	W	1700		
	RATED RUNNING CURRENT (COOLING)	A	7.5		
	RATED RUNNING CURRENT (HEATING)	A	7.61		
	LOCKED ROTOR AMP.	A	30		

1) ALL SPECIFICATION ARE SUBJECTED TO CHANGE BY THE MANUFACTURER WITHOUT PRIOR NOTICE

2) ALL UNITS ARE BEING TESTED AND COMPLY TO ISO 5151.

3) ALL SPECIFICATION ARE TENTATIVE SPECIFICATION AT THE TIME OF PRINTING. PLEASE CONSULT YOUR DEALER FOR CONFIRMATION.

Wiring Diagrams

Indoor Unit
Model : M5MSX 020AR

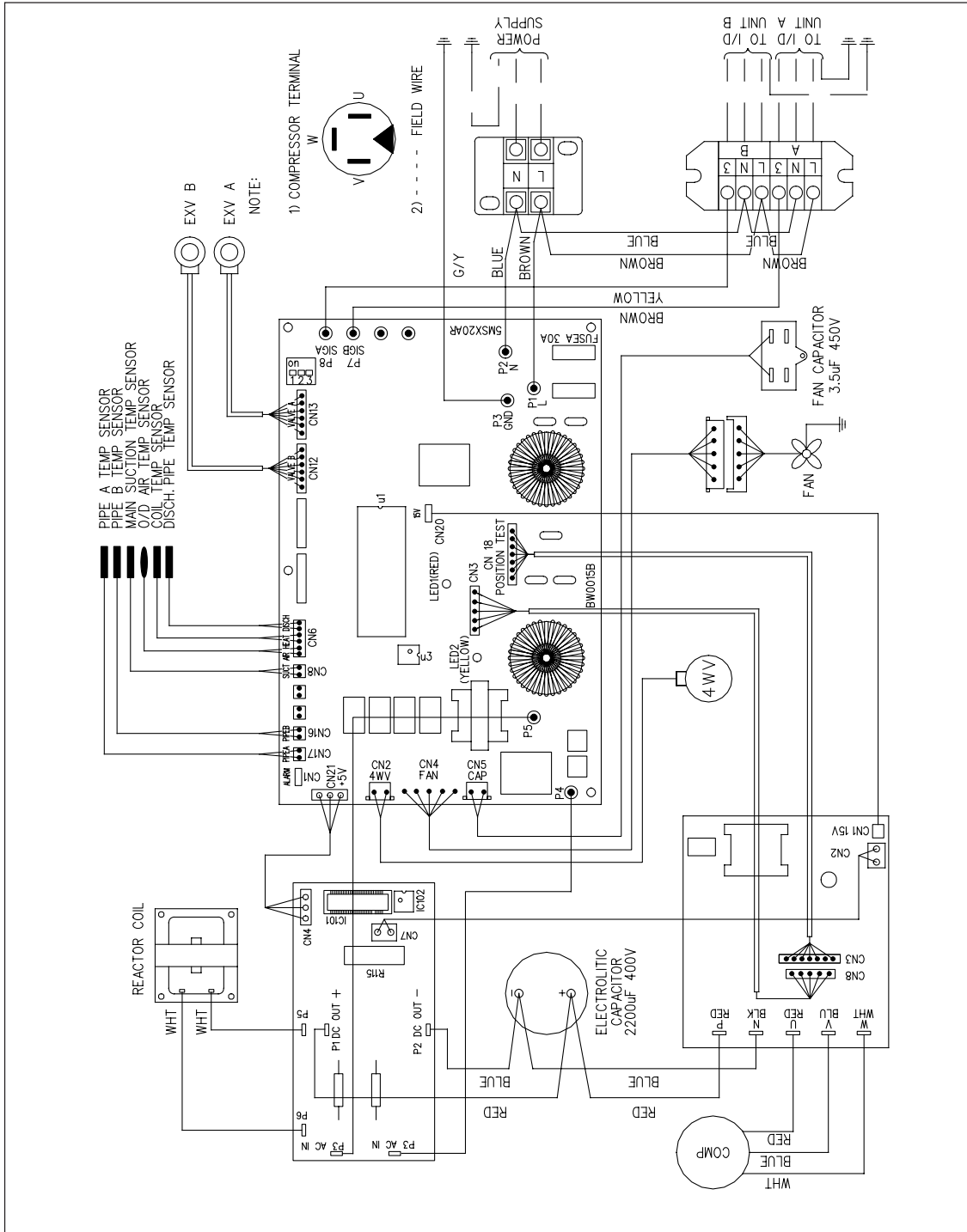

Indoor Unit

Model : M5MSX 025AR

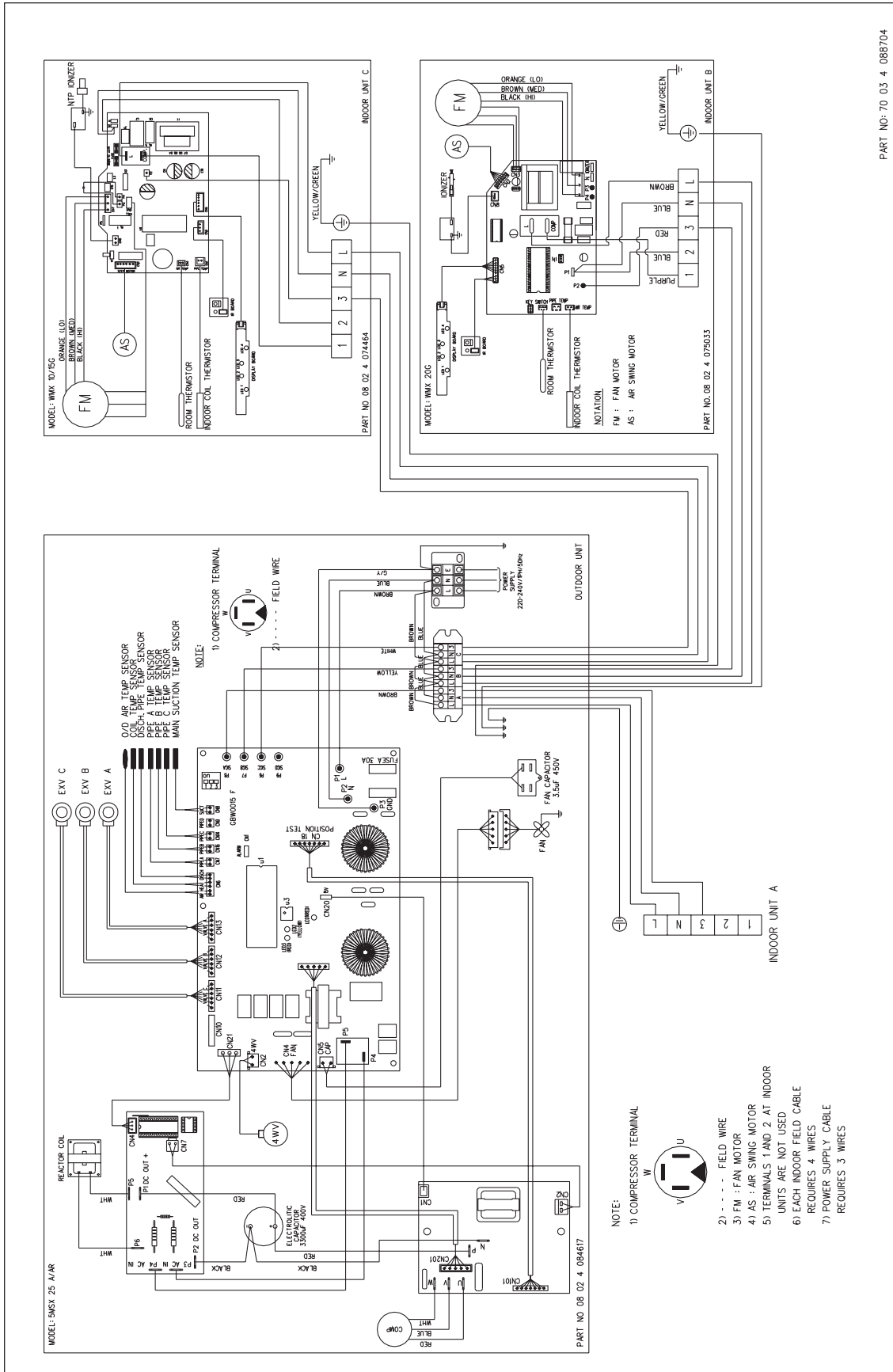

PART NO. 70 03 4 088704

Model : M5MSX 030AR

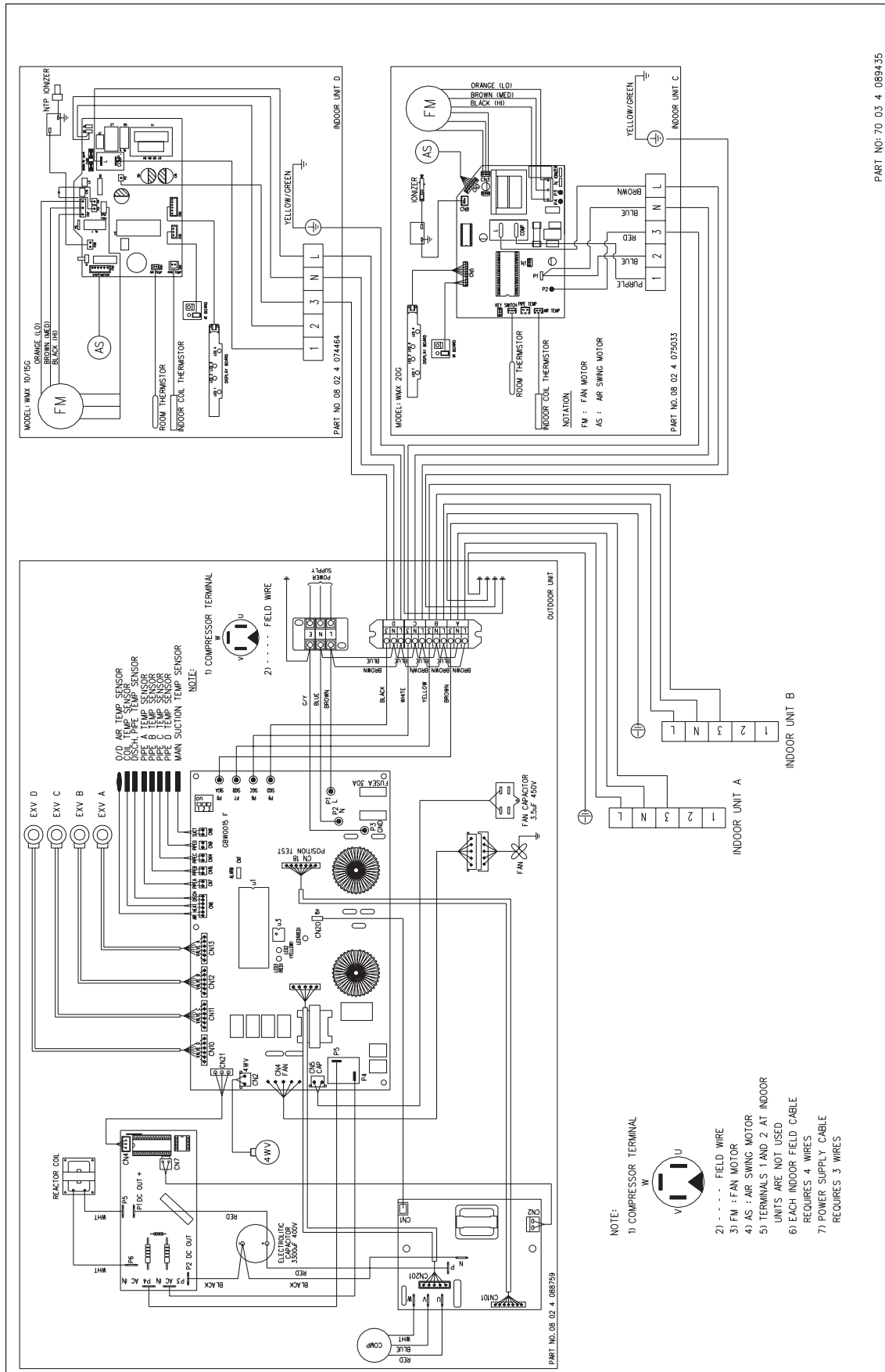

PART NO: 70 03 4 089435

Servicing and Maintenance

Service Parts	Maintenance Procedures	Period
Indoor air filter	<ol style="list-style-type: none"> 1. Remove any dust adhering to the filter by using a vacuum cleaner or wash in lukewarm water (below 40°C) with a neutral cleaning detergent. 2. Rinse the filter well and dry before placing it back onto the unit. 3. Do not use gasoline, volatile substances or chemicals to clean the filter. 	At least once every 2 weeks. More frequently if necessary.
Indoor unit	<ol style="list-style-type: none"> 1. Clean any dirt or dust on the grille or panel by wiping it off with a soft cloth soaked in lukewarm water (below 40°C) and a neutral detergent solution. 2. Do not use gasoline, volatile substances or chemicals to clean the indoor unit 	At least once every 2 weeks. More frequently if necessary.

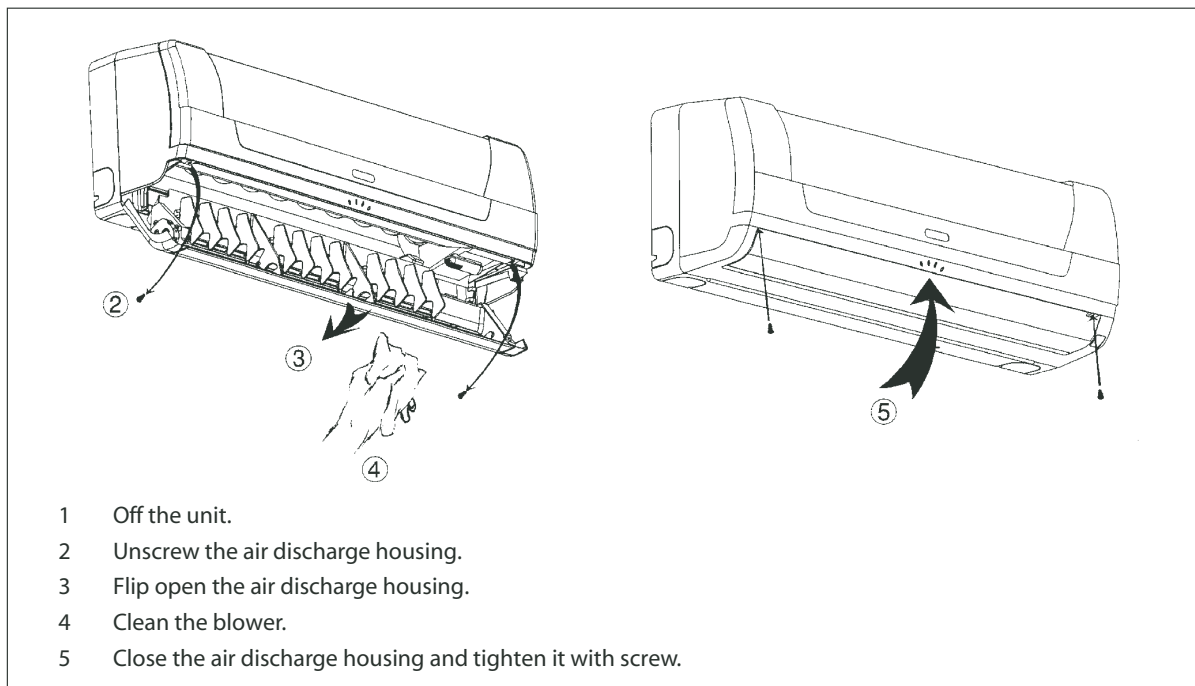

! Caution

Do not operate any heating apparatus too close to the air conditioner unit. This may cause the plastic panel to melt or deform as a result of the excessive heat.

WHEN THE UNIT IS NOT USED FOR AN EXTENDED PERIOD OF TIME

Operate the unit for 2 hours with the following setting.

Operating mode : cool
Temperature : 30°C

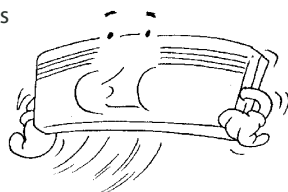

Remove the power plug.
If you are using an independent electric circuit for your unit, cut off the circuit.
Remove the batteries in the remote control.

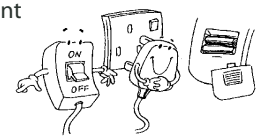

Troubleshooting

If there is any malfunction of the air conditioner unit detected, please switch off the main power supply immediately before proceeding with the following troubleshooting procedures as safety precautions.

The following are some common fault conditions and simple troubleshooting tips. If encounter any faulty conditions which are not listed, please contact nearest dealer or service maintenance. DO NOT attempt to troubleshoot the unit by yourself.

No	Fault conditions	Possible causes / corrective actions
1	The air conditioner unit will not start straight away after a power failure or restart unit.	<ul style="list-style-type: none"> The air conditioner unit has a 3 minutes restart protection. Please wait for the unit to restart by leaving the main power on.
2	The compressor does not operate 3 minutes after the air conditioner unit is started.	<ul style="list-style-type: none"> Protection against frequent starting. Wait for 3 or 4 minutes for the compressor to start operating by it self.
3	The airflow is too slow or room cannot be cooled sufficiently.	<ul style="list-style-type: none"> The air filter is dirty. The doors and windows are opened. The air suction and discharge of both indoor and outdoor units are clogged or blocked. The regulated temperature or temperature setting is not low enough.
4	Discharge airflow has bad odor.	<ul style="list-style-type: none"> Odour may be cause by cigarettes, smoke particles, perfume and others, which might have adhered onto the coil. Contact your nearest dealer.
5	Condensation on the front air grille of the indoor unit.	<ul style="list-style-type: none"> This is caused by air humidity after an extended period of operation. The set temperature is too low. Increase the temperature setting and operate the unit at high fan speed.
6	Water flowing out from the air conditioner.	<ul style="list-style-type: none"> Switch off the unit and contact your nearest dealer. This might be due to tilted installation.
7	Hissing airflow sound from the air conditioner unit during operation.	<ul style="list-style-type: none"> Liquid refrigerant flowing into the evaporator coil.
8	The indoor unit's LED indication keeps blinking.	<ul style="list-style-type: none"> Check the fault indication listed under section INDICATOR LIGHTS. If LED display indicates defrost operation, ignore it. This shows that the outdoor unit is defrosting the ice at the outdoor unit. For other LED display, follow the COMPRESSOR STOPPED TROUBLESHOOTING INSTRUCTIONS at next section.
9	The outdoor unit will not operate and the indoor unit's LED indication does not blink.	<ul style="list-style-type: none"> Power failure or fuse needs to be replaced. Check power supply. The main power plug is disconnected or the circuit breaking is turned off. It is possible that the delay timer has been set incorrectly. If the problem persists after all these verifications, follow the COMPRESSOR STOPPED TROUBLESHOOTING INSTRUCTIONS at next section.

Normal Running Mode condition

If the air conditioner unit has no faulty indications and the compressor is running at normal mode, the outdoor P.C. Board's LED indication will blink at a slower pace. The table below shows the significant meaning of different running mode and limitation for this air conditioner unit.

One must not attempt to see the LED indication blinking unless instructed to do so.

Blinks	Blinking Indication
1	Normal running, with no limitation
2	Voltage limit
3	Cooling unit : Outdoor coil temperature limit Heating unit : Indoor coil temperature limit
4	Total current limit
5	Discharge temperature unit
6	Cooling unit : Indoor coil temperature limit
7	Indoor fan control
8	Outdoor frequency adjustment

Compressor stopped error indication and troubleshooting guide

If the compressor stop unexpectedly, the outdoor P.C.Board's LED indication will blink accordingly to the error it detects. The table below shows the meaning according to the number of LED blinking and the corrective action that one should take.

Blink		Fault Indication	Corrective Action
RED	YELLOW		
LED	LED		
0	1	Outdoor ambient sensor error	Check outdoor ambient sensor wire and connection
0	2	Outdoor coil sensor error	Check outdoor coil sensor wire and connection
0	3	Outdoor discharge sensor error/ Compressor overheat indication	Check outdoor discharge sensor wire and connection/ Check pressure and compressor/Not enough refrigerant/ indoor overload
0	4	DC compressor feedback error	Check compressor wire and feedback wire
0	5	Communication error	Check communication wire and connection for both indoor and outdoor
0	6	Over current error	Check total current:check pressure and compressor
0	7	No load	Ignore
0	8	Over/ under voltage	Check power supply
0	9	DC compressor start failure	Check compressor wire and feedback wire;check compressor
1	0	Cooling overload	Check whether outdoor unit is blocked or not;check pressure
1	1	Defrost	Ignore
1	2	IPM Protection	Check power supply; check main board/filter board; check bridge diode; check IPM board; check compressor
1	3	EEPROM	Check EEPROM chip connection
1	4	EEPROM write error	Check EEPROM chip connection
1	5	DC fan motor no feed back	Check fan motor wire connection
1	6	AC peak current error	
1	7	Outdoor suction sensor error	Check outdoor suction sensor wire and connection
1	9	DC compressor speed control error	Check IPM board; check compressor
2	1	Outdoor suction A sensor error	Check suction sensor wire pipe A and connection
2	2	Outdoor suction B sensor error	Check suction sensor wire pipe B and connection
2	3	Outdoor suction C sensor error	Check suction sensor wire pipe C and connection
2	4	Outdoor suction D sensor error	Check suction sensor wire pipe D and connection
3	1	Indoor A communication error	Check communication wire and connection with indoor A
3	2	Indoor B communication error	Check communication wire and connection with indoor B
3	3	Indoor C communication error	Check communication wire and connection with indoor C
3	4	Indoor D communication error	Check communication wire and connection with indoor D

Troubleshooting Progress

If the air conditioner is not operating normally, One should follow the troubleshooting steps as stated in the flow chart below

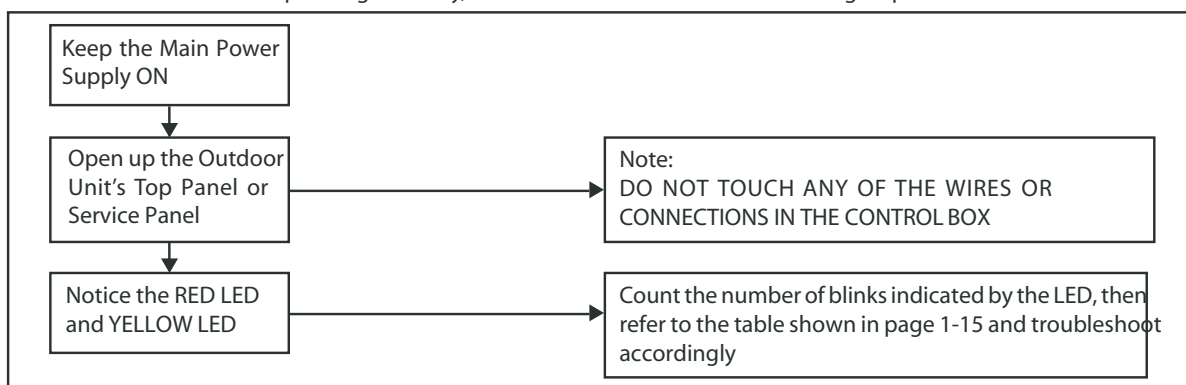

Check Point (1) – Power Supply

Step-by-step troubleshooting guide for power supply checking.

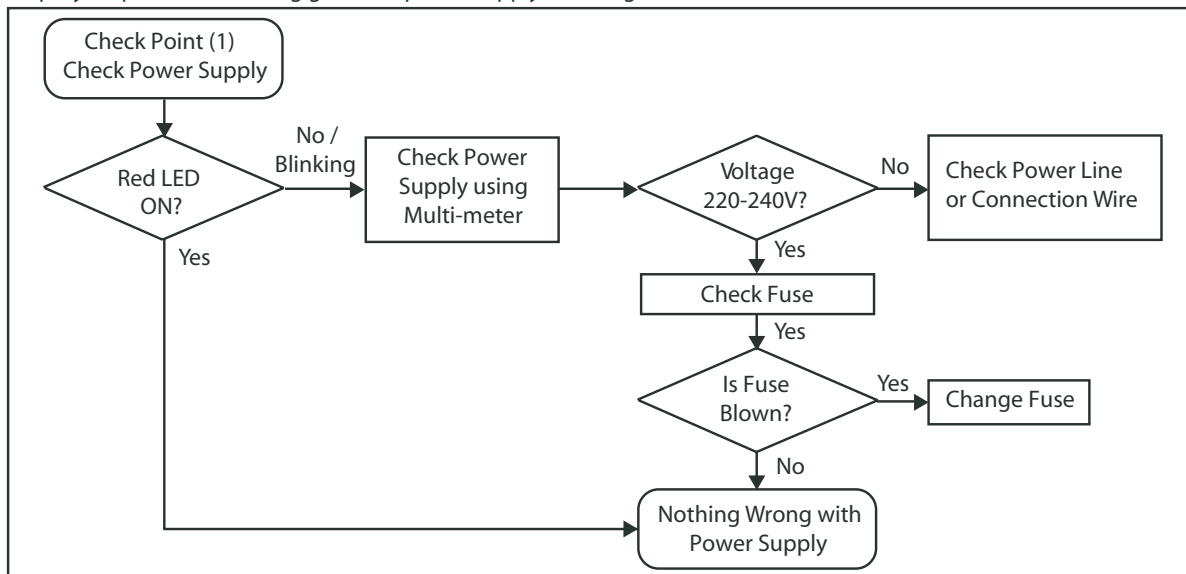

Check Point (2) – Bridge Diode

Step-by-step troubleshooting guide for identifying bridge diode error.

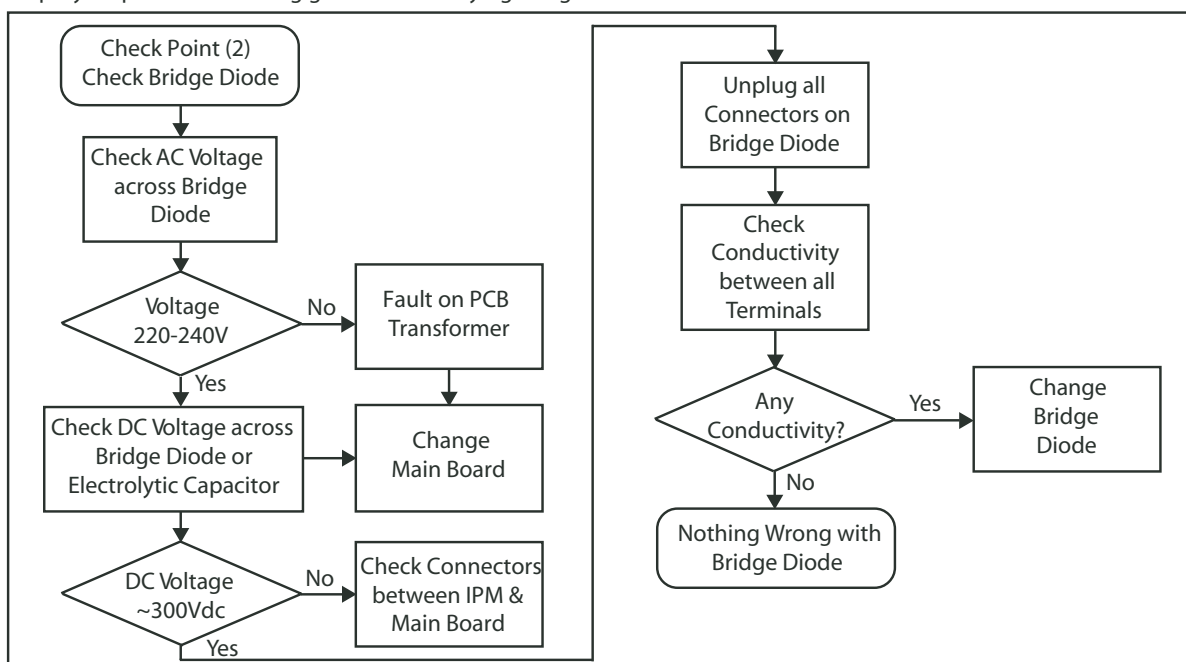

Check Point (3) – IPM Board

Step-by-step troubleshooting guide for identifying IPM Board error.

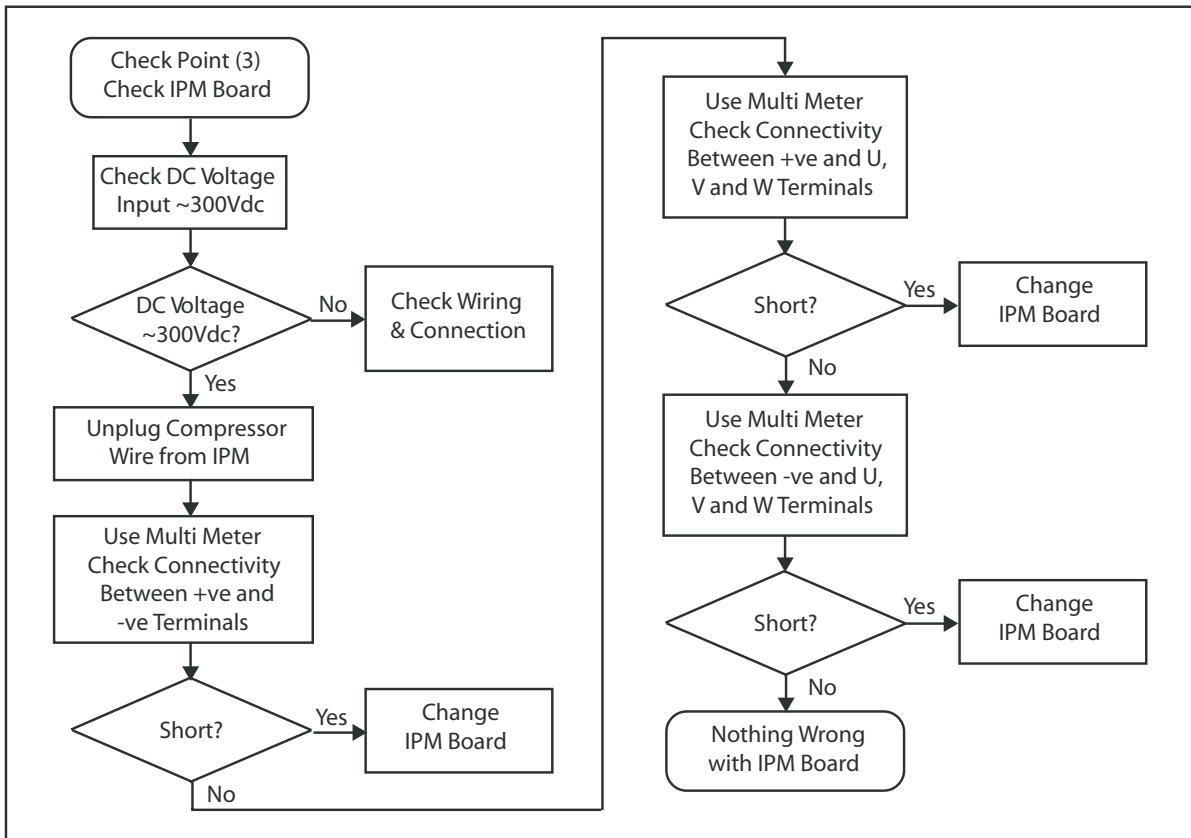

Check Point (4) – Compressor

Step-by-step troubleshooting guide for identifying compressor failure.

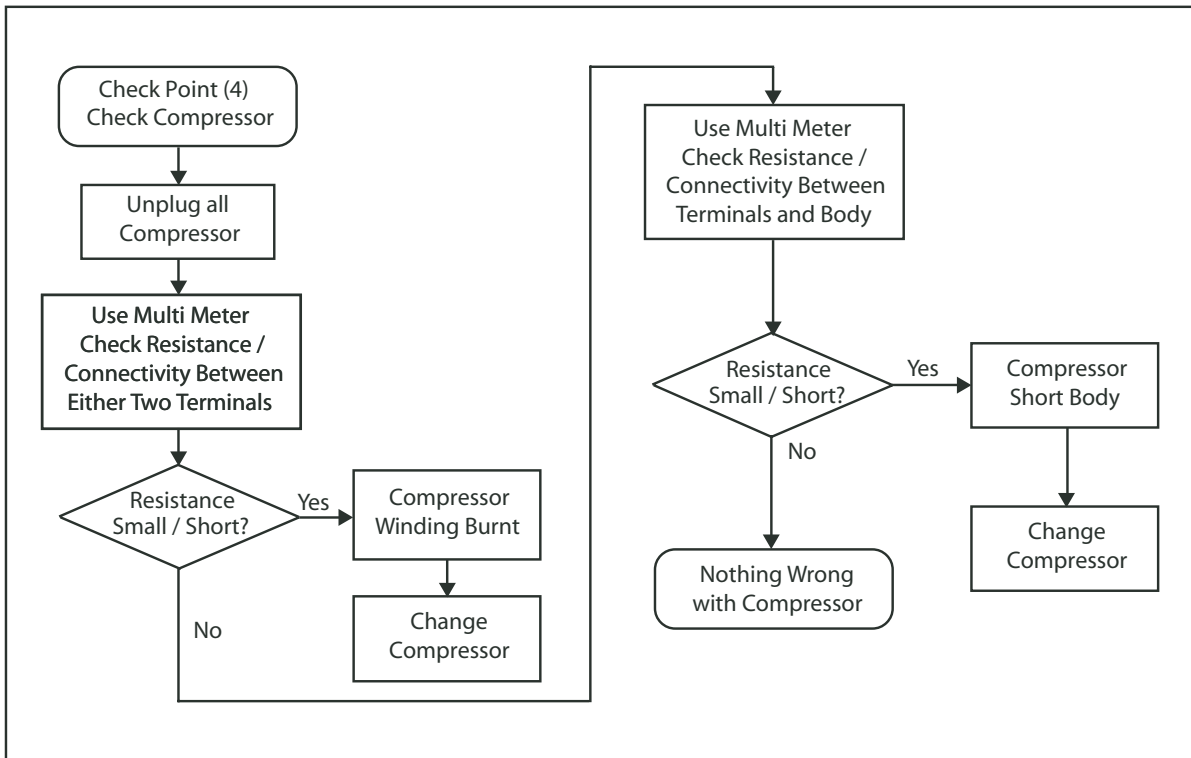

Exploded View and Parts List

Model : M5WMX 010 / 015 G/GR

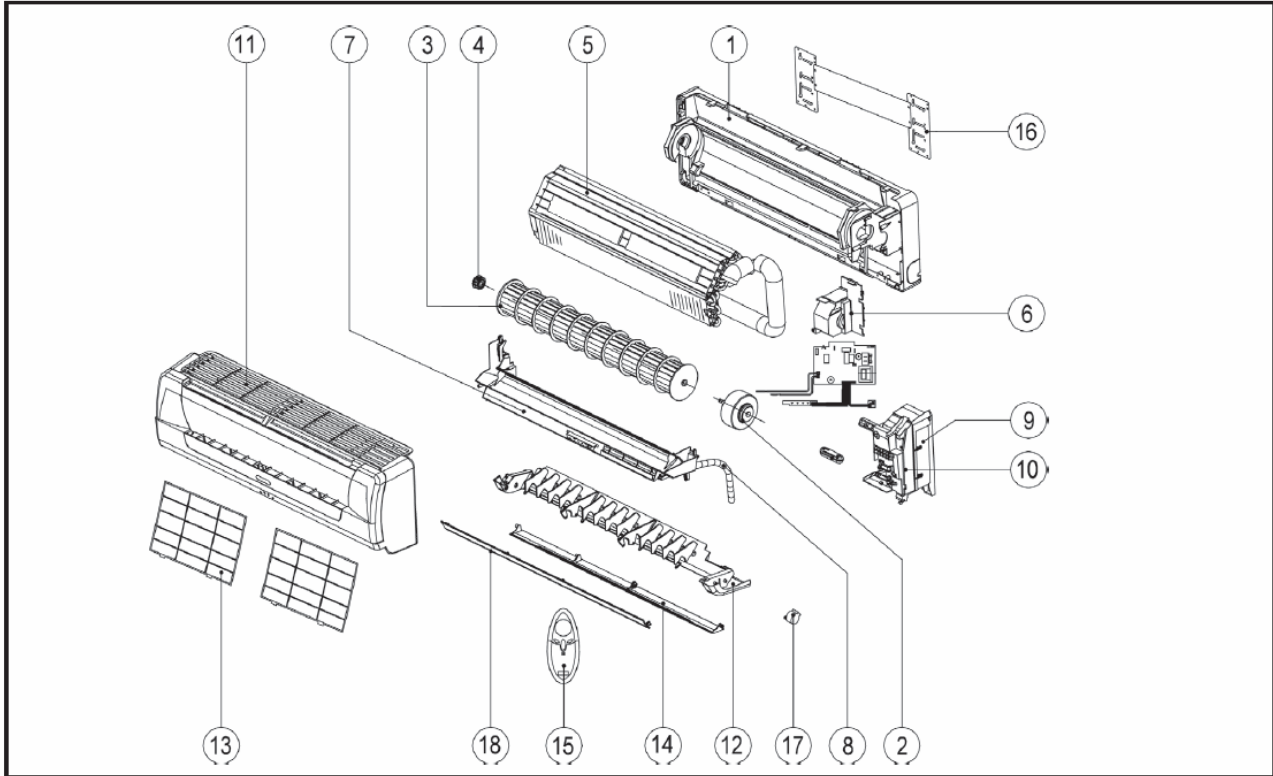

No	Description	Part Number	Related Model			
			M5WMX 010G	M5WMX 010GR	M5WMX 015G	M5WMX 015GR
1	ASSY, CHASSIS 10/15G	R50124064151	√	√	√	√
2	Motor WMX10/15G 17w Welling	R03039022520	√	√	√	√
3	BLOWER,CROSS FLOW G97-717.5 SUNWILL	R03029019461	√	√	√	√
4	FAN BUSH C/FLOW BLACK	R11014029514	√	√	√	√
5	ASSY, INDOOR COIL - WM10GR	R50024064225	√	√		
	ASSY, INDOOR COIL - WM15GR	R50024066054			√	√
6	PIPING CLAMP	R12014060544	√	√		
7	ASSY, DRAIN PAN 10/15G	R50124064152	√	√	√	√
8	DRAIN HOSE WM10/15(600mmL)	R10024018204	√	√	√	√
9	ASSY, CONTROL BOX COVER (AP)	R50124074815	√	√	√	√
10	ASSY, CONTROL BOX 10G-ION OYLT	R50044083997	√			
	ASSY, CONTROL BOX 10GR-ION OYLT	R50044083999		√		
	ASSY, CONTROL BOX 15G-ION OYLT	R50044083998			√	
	ASSY, CONTROL BOX 15GR-ION OYLT	R50044084000				√
11	ASSY., FRONT COVER A 5WMX10/15G/GR	R50124085074	√	√	√	√
12	ASSY, AIR DISCHARGE 10/15	R50124062326	√	√	√	√
13	FILTER 10/15G	R12014062321	√	√	√	√
14	LOUVER BOTTOM 10/15G	R12014061364	√	√	√	√
15	HANDSET, WIRELESS G11 AP MCQUAY	R04084067314	√	√	√	√
16	ASSY, MOUNTING PLATE 10/15G	R50014062324	√	√	√	√
17	MOTOR, AIR SWING WM10/15G	R03039021375	√	√	√	√
18	LOUVER TOP 10/15G	R12014061363	√	√	√	√

Model : M5WMX 020G/GR

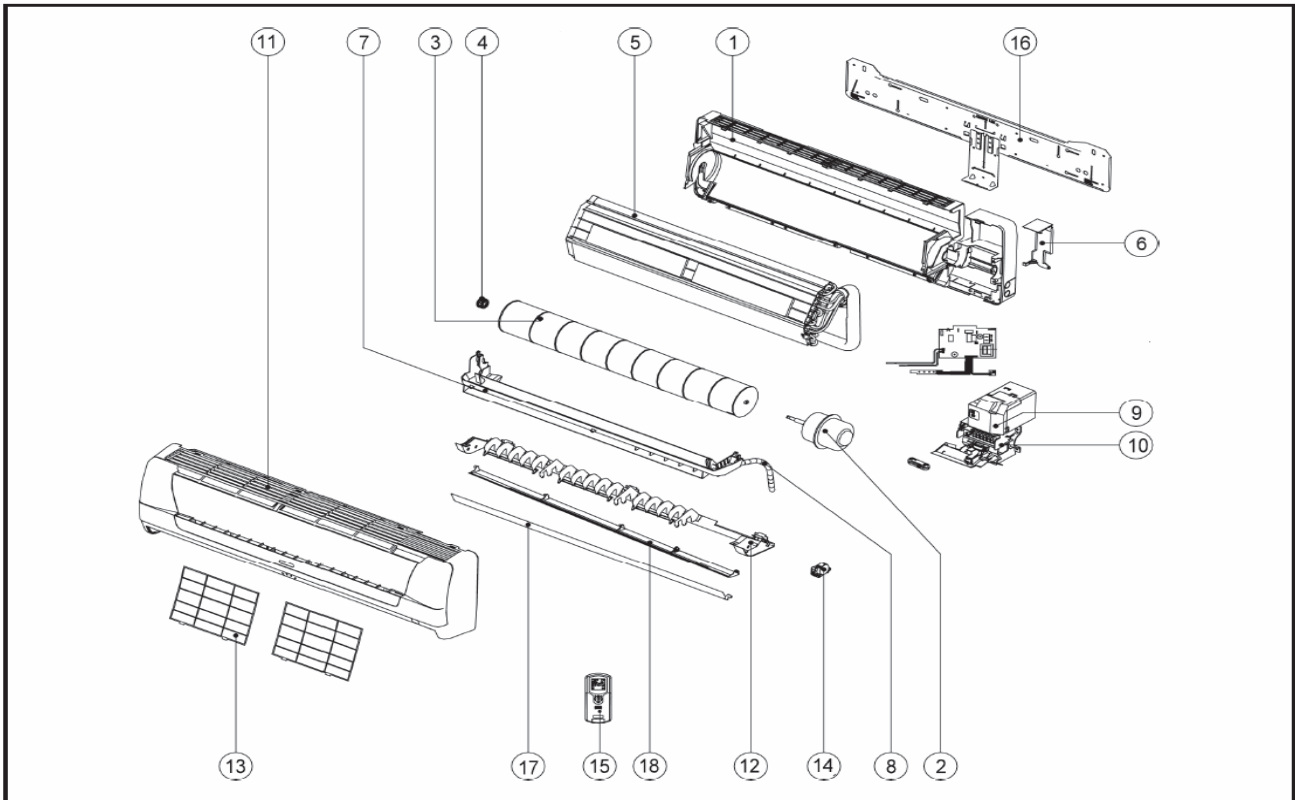

No	Description	Part Number	Related Model	
			M5WMX 020G	M5WMX 020GR
1	Assy, Chassis WM20/25G	R50124068170	√	√
2	Motor, MWMX20/20G	R50034074747	√	√
3	FAN CROSS FLOW, WM20/25F	R03029029158	√	√
4	Fan Bush C/Flow Grey	R11014023775	√	√
5	Assy, Coil WM20G/GR / 5WM25G/R	R50024072203	√	√
6	Clamp, Piping 20/25G	R12014071297	√	√
7	Assy, Drain Pan 20/25G	R50124068171	√	√
8	Drain Hose Assy WM20C/25C(700mmL)	R10024015319	√	√
9	Assy, Control Box Cover 20/25G (EC)	R50124074814	√	√
10	ASSY, CONTROL BOX (ION 5WMX 20G)	R50044085630	√	
	ASSY, CONTROL BOX (ION 5WMX 20GR)	R50044085632		√
11	ASSY,F/COVER-A	R50124074743	√	√
12	ASSY, AIR DISCHARGE 20/25G	R50124071426	√	√
13	FILTER, NANOSILVER 20/25G (WITH FRAME)	R12014080142	√	√
	FILTER, NANOVIS 20/25G (WITH FRAME)	R12014080144	√	√
14	Motor, MP35 WM20/25G	R03039022933	√	√
15	HANDSET, WIRELESS G11 EC W/IONIZER MCQUAY	R04084065334	√	√
16	Assy, Mtg Plate WM20/25F	R50014036133	√	√
17	Louver, Top 20/25G	R12014066820	√	√
18	Louver, Bottom 20/25G	R12014066821	√	√

Model : M5MSX 020A/AR

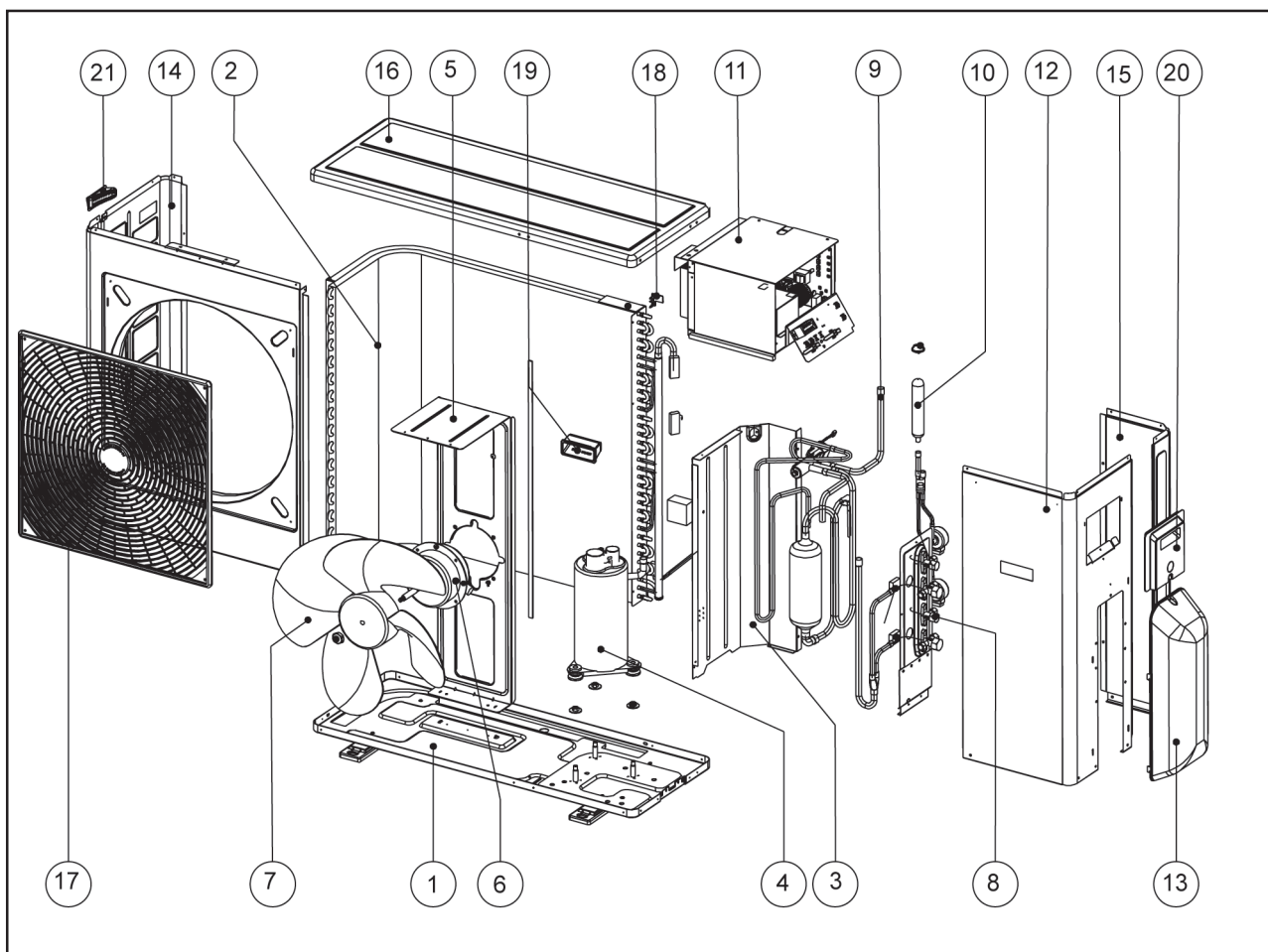

No	Description	Part Number	Related Model	
			M5MSX 020A	M5MSX020AR
1	Assy, Base Pan (5SLX20/25CR)	R50014073830	✓	✓
2	Assy, Condenser Coil (5MSX20AR)	R50024071636	✓	✓
3	Panel, Partition	R01014072818	✓	✓
4	Assy, Comprssor 5CS130XCC03	R50049024264	✓	✓
5	Bracket Motor (SL25C/28C/CR)	R01014070948	✓	✓
6	Motor, M5MSX20AR-501-K 64W	R03039024770	✓	✓
7	Fan Propeller, Ø460 0Z40700	R03019023393	✓	✓
8	ASSY., VALVE BRACKET	R50024088110	✓	
	Assy, Valve Bracket (5MSX20AR)	R50024074217		✓
9	Assy, 4Way Valve(5MSX20AR)	R50024074210		✓
10	Filter Drier, STS2258 KYOSEKI SANGYO	R02169024287	✓	✓
11	ASSY, CONTROL BOX (5MSX20A)	R50044088427	✓	
	Assy, Control Box (5MSX20AR)	R50044072830		✓
12	Assy, Panel Service	R50014076979	✓	✓
13	Valve Cover, MSD/MSH/MST	R12014057544	✓	✓
14	Panel Front / Left	R01014070947	✓	✓
15	Panel Right Back (SL25C/28C/CR)	R01014070950	✓	✓
16	Panel Top (SL20C/25C/28C/CR)	R01014070596	✓	✓
17	Assy Front Grille (SL20C/25C/28C/CR)	R50124072880	✓	✓
18	Thermister Holder WM10/15	R12014016707	✓	✓
19	Plastic,Handle SL07C/09C/10C/15C/CR	R12014057948	✓	✓
20	Access Panel C/W Ins SL	R50124017615	✓	✓
21	Plastic Handle Front (SL25C/28C/CR)	R12014070955	✓	✓
Parts not in Diagram				
	Assy, Capillary Tube (5MSX20AR)	R50024074209	✓	✓
	Valve, Rev 4 Way SHF-7H-34U(RK)	R05019016937	✓	✓
	Valve, Flare 2Way 1/4" (R410A)	R50054074219	✓	✓
	Valve, Flare 3Way 3/8" (R410A)	R50054074218	✓	✓
	Valve, EXV ZDPF(L) 1.6C-10-RK(E)	R05019024212	✓	✓
	Accumulator,DIA70.2 x OD16 x t1.2	R02114066381	✓	✓

Model : M5MSX 025A/AR

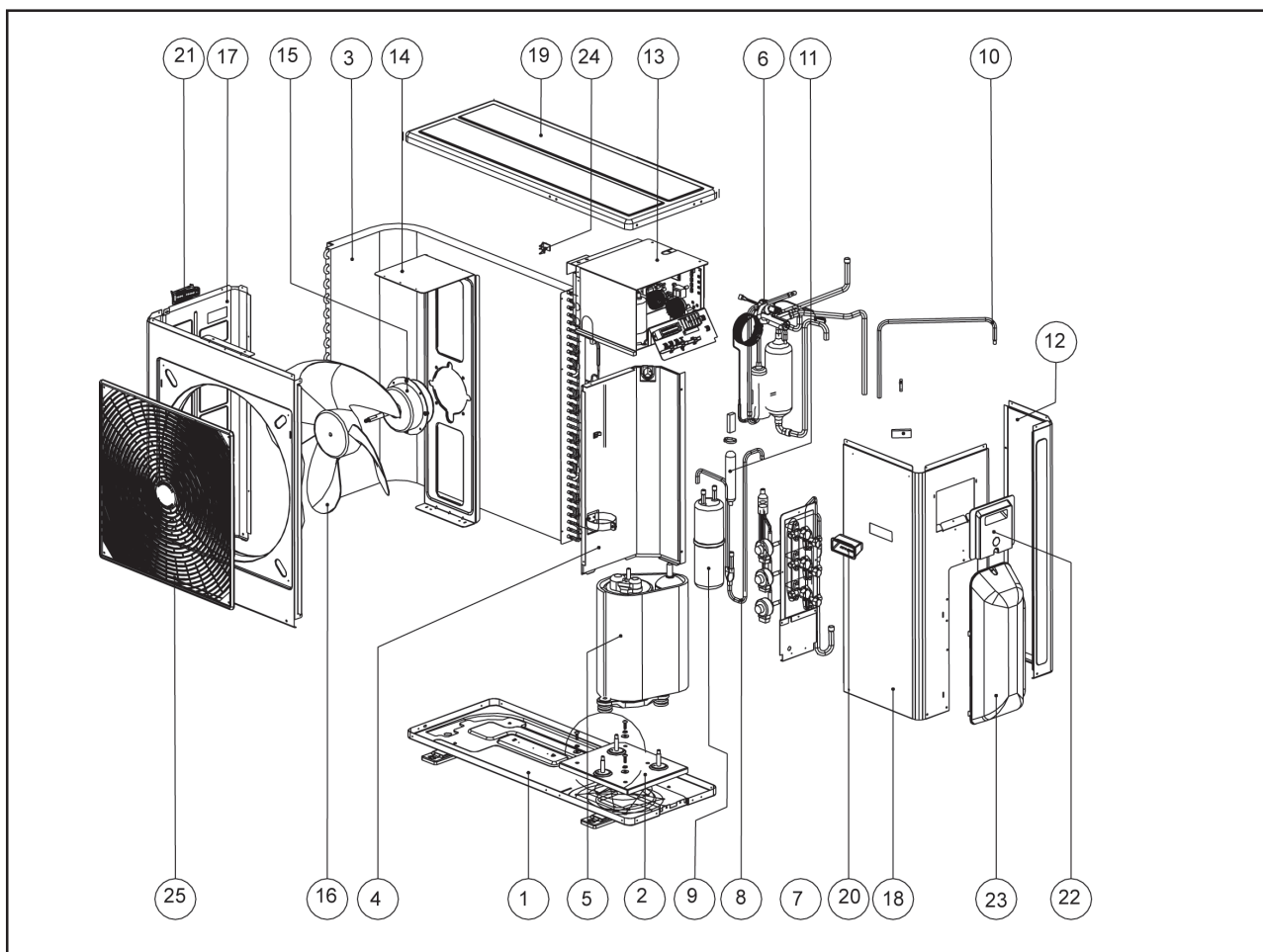

No	Description	Part Number	Related Model	
			M5MSX 025A	M5MSX025AR
1	ASSY., BASE PAN (5MSX25/30AR)	R50014081766	√	√
2	ASSY., COMP. MOUNT. PLATE	R50014081839	√	√
3	ASSY., CONDENSER COIL	R50024082873	√	√
4	PANEL, PARTITION	R01014072818	√	√
5	COMPRESSOR, ASSY 5KD240XAA21 MATSUSHITA	R50049025599	√	√
6	VALVE, REV 4 WAY SHF-7H-34U(RK) SHANHUA	R05019016937	√	√
7	ASSY., VALVE BRACKET	R50024082278	√	√
8	ASSY., FILTER DRIER	R50024082277	√	√
9	LIQUID RECEIVER, QFQ1.0-B-02 TONG LI	R02119026013	√	√
10	TUBE, LIQ. REC. TO CONDENSER	R02014082177	√	√
11	FILTER DRIER, STS2258 KYOSEKI SANGYO	R02169024287	√	√
12	PANEL RIGHT BACK (SL25C/28C/CR)	R01014070950	√	√
13	ASSY, CONTROL BOX 5MSX25A	R50044088428	√	√
	ASSY, CONTROL BOX 5MSX25AR	R50044083786		√
14	BRACKET MOTOR (SL25C/28C/CR)	R01014070948	√	√
15	MOTOR, M5SLX25CR-501-K 94W KUSATSU	R03039024771	√	√
16	FAN PROPELLER, Ø460 0Z40700 SUNWILL CHIN	R03019023393	√	√
17	PANEL FRONT / LEFT	R01014070947	√	√
18	ASSY, PANEL SERVICE	R50014076979	√	√
19	PANEL TOP (SL20C/25C/28C/CR)	R01014070596	√	√
20	HANDLING HANDLE SL/MSS	R12014015328	√	√
21	PLASTIC HANDLE FRONT (SL25C/28C/CR)	R12014070955	√	√
22	ACCESS PANEL C/W INS SL	R50124017615	√	√
23	VALVE COVER, MSD/MSH/MST	R12014057544	√	√
24	THERMISTER HOLDER WM10/15	R12014016707	√	√
25	ASSY FRONT GRILLE (SL20C/25C/28C/CR)	R50124072880	√	√
	ASSY., CAP TUBE	R50024082874	√	√
	COMPRESSOR JACKET (t6mm x 660.0 x 300.0)	R06074082332	√	√
	ACCUMULATOR, DIA70.2 x OD16 x t1.2	R02114066381	√	√

MODEL : M5MSX 030A/AR

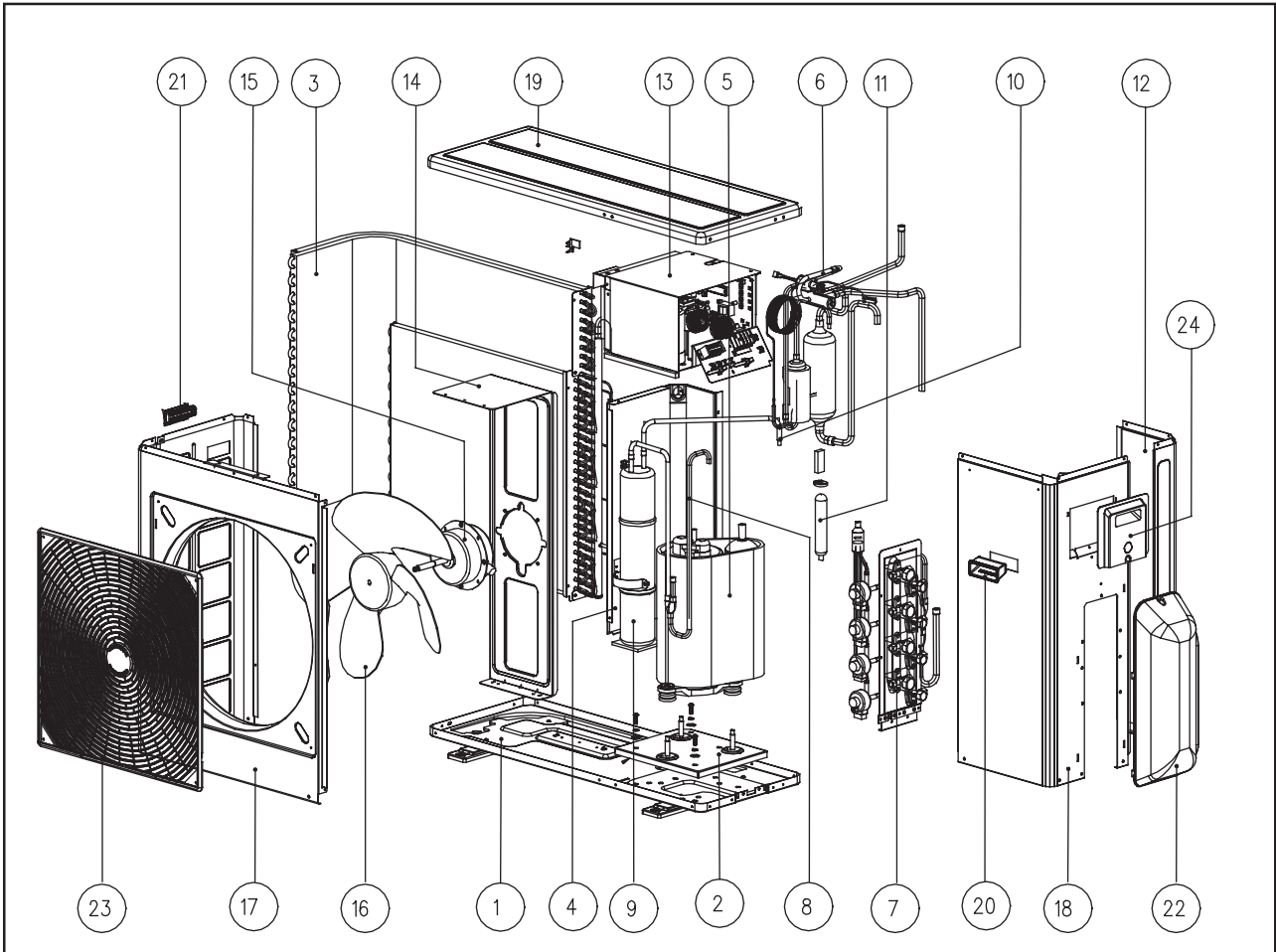

No.	Description	Part Number	Related Model	
			M5MSX 030AR	M5MSX 030AR
1	R50014081766	ASSY., BASE PAN (5MSX25/30AR)	√	√
2	R50014081839	ASSY., COMP. MOUNT. PLATE	√	√
3	R50024082173	ASSY., CONDENSER COIL (5MSX30AR)	√	√
4	R01014082178	PANEL PARTITION	√	√
5	R50049025599	COMPRESSOR, ASSY 5KD240XAA21 MATSUSHITA	√	√
6	R02114066381	ACCUMULATOR, DIA70.2 x OD16 x t1.2	√	√
	R05019016937	VALVE, REV 4 WAY SHF-7H-34U(RK) SHANHUA	√	√
7	R50024081869	ASSY., VALVE BRACKET	√	√
8	R50024088175	ASSY., FILTER DRIER	√	√
9	R50064088183	ASSY., LIQUID RECEIVER	√	√
10	R02014088177	TUBE, LIQ. REC. TO CONDENSER	√	√
11	R02169024287	FILTER DRIER, STS2258 KYOSEKI SANGYO	√	√
12	R01014070950	PANEL RIGHT BACK (SL25C/28C/CR)	√	√
13	R50044083787	ASSY., CONTROL BOX (5MSX30AR)	√	√
14	R01014070948	BRACKET MOTOR (SL25C/28C/CR)	√	√
15	R03039024771	MOTOR, M5SLX25CR-501-K 94W KUSATSU	√	√
16	R03019023393	FAN PROPELLER, Ø460 0Z40700 SUNWILL CHIN	√	√
17	R01014070947	PANEL FRONT / LEFT	√	√
18	R50014076979	ASSY, PANEL SERVICE	√	√
19	R01014070596	PANEL TOP (SL20C/25C/28C/CR)	√	√
20	R12014070955	PLASTIC HANDLE FRONT (SL25C/28C/CR)	√	√
21	R12014015328	HANDLING HANDLE SL/MSS	√	√
22	R12014057544	VALVE COVER, MSD/MSH/MST	√	√
23	R50124072880	ASSY FRONT GRILLE (SL20C/25C/28C/CR)	√	√
24	R50124017615	ACCESS PANEL C/W INS SL	√	√
Parts not in Diagram				
	R50024082293	ASSY., CAP TUBE	√	√
	R06074082332	COMPRESSOR JACKET (t6mm x 660.0 x 300.0)	√	√
	R12014016707	THERMISTER HOLDER WM10/15	√	√
	R04084084668	CONTROL MODULE, 5MSX30AR-D2PAA	√	√
	R04084084667	CONTROL MODULE, BW0060B IPM	√	√
	R04084084669	CONTROL MODULE, BW0024B-PFC50AA PFC	√	√

Products manufactured in an ISO certified facility.
This document contains the most current product information as of this printing. For the most up-to-date product information, please go to www.mcquay.com.



© 2008 McQuay International

+1 (800) 432-1342

www.mcquay.com



Большая библиотека технической документации
<https://splitsystema48.ru/instrukcii-po-ekspluatácii-kondicionerov.html>
каталоги, инструкции, сервисные мануалы, схемы.